

TEST CONDITIONS:
 1 GAIN, MASTER @ 10
 2 TONES @ 5
 3 BUTTONS OUT
 4 1kHz SIGNAL IN (25mV p-p)

Power Table				
Ref Des	Device(Type)	Package	-16V	+16V
IC1	3707201_	8DIP_3	4	8
IC2	3707201_	8DIP_3	4	8
IC3	3707201_	8DIP_3	4	8

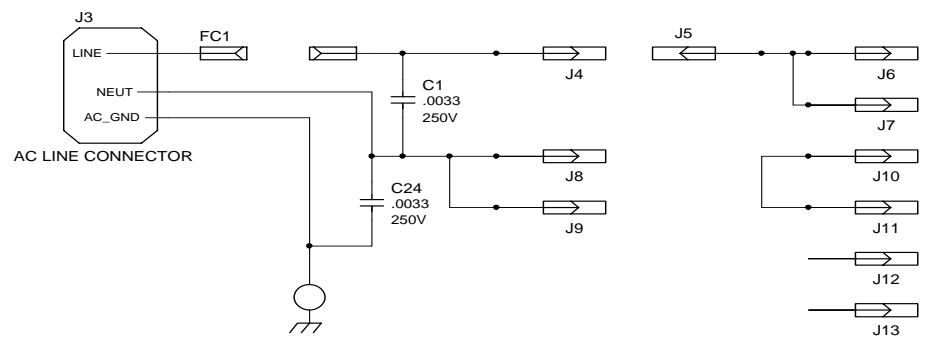

CAUTION:
 THIS SCHEMATIC IS PROVIDED FOR USE BY QUALIFIED PERSONNEL. TO AVOID RISK OF ELECTRIC SHOCK, REFER SERVICING TO QUALIFIED SERVICE PERSONNEL. DO NOT PERFORM ANY SERVICING BEYOND THAT EXPLAINED IN THE OPERATING INSTRUCTIONS.

NOTES:
 1) CAUTION: SHOCK HAZARD!! THIS UNIT CONTAINS HAZARDOUS VOLTAGE. DISCONNECT POWER AND BE SURE POWER SUPPLY IS DISCHARGED BEFORE TOUCHING INTERNAL PARTS.
 2) UNLESS NOTED, RESISTOR VALUES IN OHMS, 1/4W-5% TOL. CAPACITOR VALUES IN MICROFARADS, 50V-10% TOL.
 3) VOLTAGES ARE MEASURED WITH 1 MEGOHM OSCILLOSCOPE AND 10 MEGOHM DIGITAL VOLTMETER.

REV	Date	DESCRIPTION	Ecr(s)/Ecn(s)	Chgd By	Appvd by	Date
0	10/28/04	CONTROL ISSUE			WFB	
A	06/21/04	INITIAL ISSUE			WFB	

THE INFORMATION CONTAINED ON THIS DRAWING IS PROPRIETARY TO ST. LOUIS MUSIC, INC.

Signatures:		Date:
Drawn:	WFB	04/08/04
Checked:		
Released:		

1901 Congressional, St. Louis, MO 63146

Plot Date: Thu Oct 28, 2004	Drawing Size: C	Drawing Title: BASS PREAMP
Plot Time: 08:56:32	Drawing Type: Schematic	Drawing Number: 07S568
Tolerance:	Class Code: NONE	Sheet 1 of 1