

Power Table

Ref Des	Device(Type)	Package	PRE_FILTER	+15V	-15V	-RAIL	CKT_GND	+15VB	-15VB	+DRIVE_12V	+12V_FLOAT
IC1	3762602_X	8DIP_3	3							6	
IC2	3762602_X	8DIP_3		3							6
IC6	37326101	SOIC8						7	4		
IC8	37327501_X	SOIC8						8	4		
IC10	37507201_DMP-8_SIOC8	DMP-8_SIOC8	8	4							
IC12	37533901_SO14N	SO14N	3					12			
IC14	37533901_SO14N	SO14N	3					12			
IC15	37507201_DMP-8_SIOC8	DMP-8_SIOC8	8	4							

CAUTION:
THIS SCHEMATIC IS PROVIDED FOR USE BY QUALIFIED PERSONNEL. TO AVOID RISK OF ELECTRIC SHOCK, REFER SERVICING TO QUALIFIED SERVICE PERSONNEL. DO NOT PERFORM ANY SERVICING BEYOND THAT EXPLAINED IN THE OPERATING INSTRUCTIONS.

- NOTES:**
- 1) CAUTION: SHOCK HAZARD!! THIS UNIT CONTAINS HAZARDOUS VOLTAGE. DISCONNECT POWER AND BE SURE POWER SUPPLY IS DISCHARGED BEFORE TOUCHING INTERNAL PARTS.
 - 2) UNLESS NOTED, RESISTOR VALUES IN OHMS, 1/10W-5% TOL. CAPACITOR VALUES IN MICROFARADS, 50V-10% TOL.
 - 3) VOLTAGES ARE MEASURED WITH 1 MEGOHM OSCILLOSCOPE AND 10 MEGOHM DIGITAL VOLTMETER.

C	06/30/06	VALUE CHANGES ONLY		WFB		
B	12/21/05	DEL L2, CHG ANALOG SECTION, R41,56		WFB		
A	02/07/05	INITIAL ISSUE				
REV	Date	DESCRIPTION	Ecr(s)/Ecn(s)	Chgd By	Appvd by	Date
THE INFORMATION CONTAINED ON THIS DRAWING IS PROPRIETARY TO ST. LOUIS MUSIC, INC						
Signatures:		Date:				
Drawn:	JT	01/20/06	1901 Congressional, St. Louis, MO 63146			
Checked:			First Used On:			
Released:						
Plot Date:	Fri Jun 30, 2006	Drawing Size:	D	Drawing Title:		
Plot Time:	09:08:42	Drawing Type:	Schematic	2500W PWR AMP		
Tolerance:		Class Code:	NONE	Drawing Number:		
		Sheet	1 of 2	06B785		

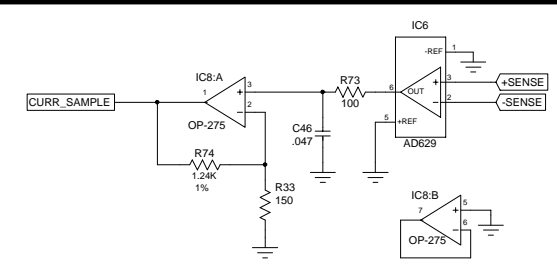

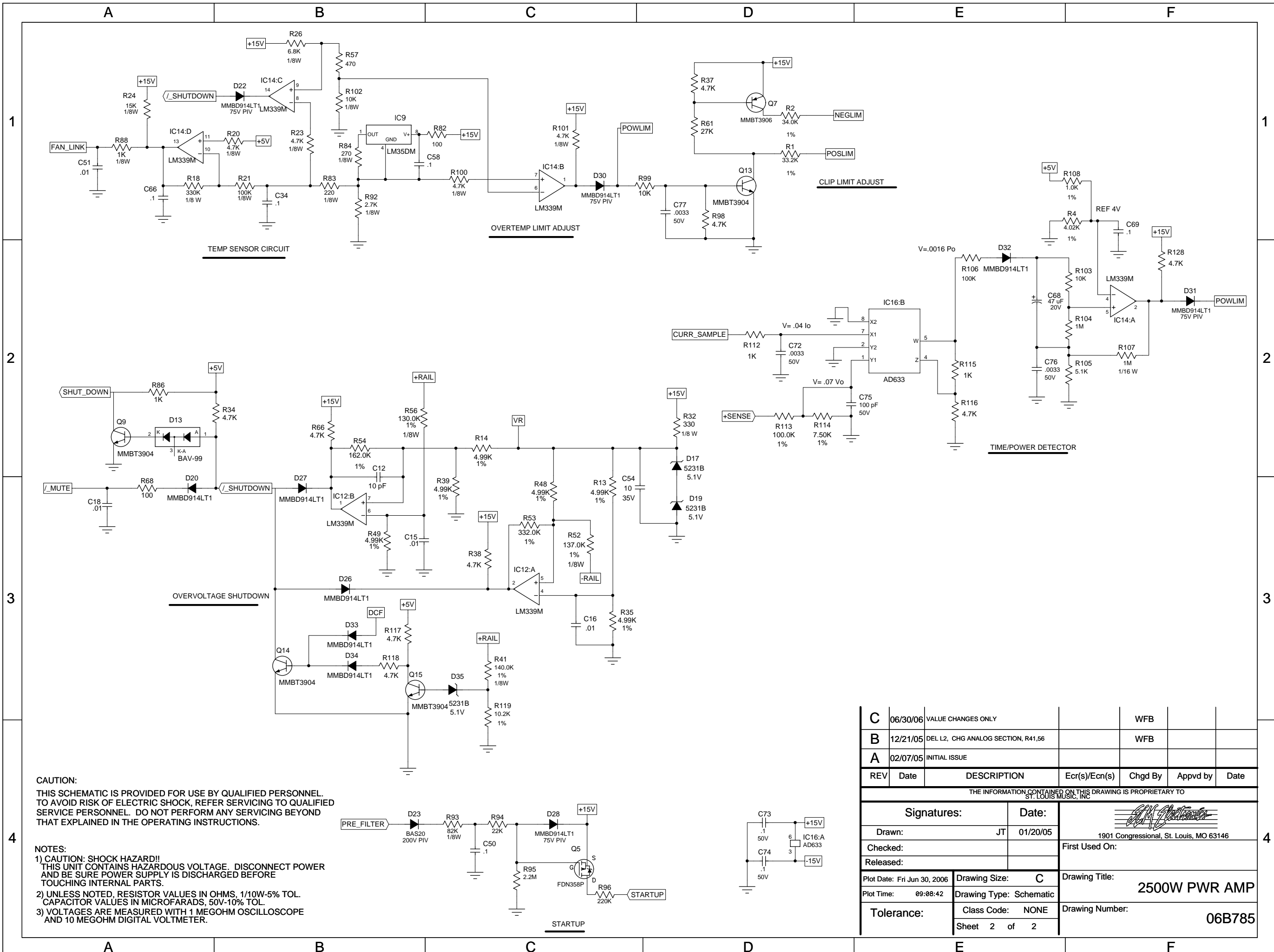

CAUTION:
 THIS SCHEMATIC IS PROVIDED FOR USE BY QUALIFIED PERSONNEL. TO AVOID RISK OF ELECTRIC SHOCK, REFER SERVICING TO QUALIFIED SERVICE PERSONNEL. DO NOT PERFORM ANY SERVICING BEYOND THAT EXPLAINED IN THE OPERATING INSTRUCTIONS.

- NOTES:**
- 1) CAUTION: SHOCK HAZARD!! THIS UNIT CONTAINS HAZARDOUS VOLTAGE. DISCONNECT POWER AND BE SURE POWER SUPPLY IS DISCHARGED BEFORE TOUCHING INTERNAL PARTS.
 - 2) UNLESS NOTED, RESISTOR VALUES IN OHMS, 1/10W-5% TOL. CAPACITOR VALUES IN MICROFARADS, 50V-10% TOL.
 - 3) VOLTAGES ARE MEASURED WITH 1 MEGOHM OSCILLOSCOPE AND 10 MEGOHM DIGITAL VOLTMETER.

C	06/30/06	VALUE CHANGES ONLY		WFB		
B	12/21/05	DEL L2, CHG ANALOG SECTION, R41,56		WFB		
A	02/07/05	INITIAL ISSUE				
REV	Date	DESCRIPTION	Ecr(s)/Ecn(s)	Chgd By	Appvd by	Date
THE INFORMATION CONTAINED ON THIS DRAWING IS PROPRIETARY TO ST. LOUIS MUSIC, INC.						
Signatures:		Date:		 1901 Congressional, St. Louis, MO 63146		
Drawn: JT		01/20/05				
Checked:						
Released:				First Used On:		
Plot Date: Fri Jun 30, 2006		Drawing Size: C		Drawing Title:		
Plot Time: 09:08:42		Drawing Type: Schematic		2500W PWR AMP		
Tolerance:		Class Code: NONE		Drawing Number:		
		Sheet 2 of 2		06B785		