

---

---

# AMPEG SERVICE MANUAL

---

---

## V9 AMPLIFIER

---

---

### V-9 AMPLIFIER SPECIFICATIONS

**Power Output:**

300 watts RMS minimum, continuous at less than 3% total harmonic distortion into 4 or 2 ohms from 20 to 20,000 Hz.

**Signal to Noise Ratio (S/N):**

-80 dB below full power

**Sensitivity:**

Channel 1 distortion circuit threshold is 800 microvolts for 10% T.H.D.

Channel 2 input sensitivity for full power is .011 volts.

**Power Supply Requirements:**

Power consumption 570 watts at rated output.

**Patching Facilities:**

Power Amp input jack is high impedance with .25 volts for 300 watts.

**Tone Control Range:**

Treble  $\pm 12$  dB @ 400 Hz.

Bass  $\pm 12$  dB @ 40 Hz.

Midrange  $\pm 20$  dB @ 300, 800 or 3,000 Hz.

Ultra Hi +12 dB @ 8,000 Hz.

(Dependent on volume control position.)

**Front Panel:**

Two inputs

Two volume controls

Bass, midrange and treble controls

Ultra hi switch

Hum balance control (on power amp chassis behind grille cloth).

Reverb and distortion controls.

Power switch

Pilot light

**Rear Panel:**

Patching jacks (in and out)

Two 4 ohm speaker jacks with automatic impedance switching

Standby switch

**Dimensions:**

23 $\frac{5}{8}$ " (65 cm.) W x 11" (23 cm.) H x

14" (36 cm.) D.

**Weight:**

88 lbs. (40 Kg.)



---

---

### V-9 SPEAKER CABINET SPECIFICATIONS:

---

---

**Power Handling:**

300 watts RMS per cabinet

**Frequency Response:**

70 Hertz - 8,000 Hertz

**Impedance:**

4 ohms.

**Speaker Complement:**

Nine 10" speakers.

**Cabinet Design:**

Vented baffle (Three compartments with three speakers per compartment).

**Dimensions:**

24" (76 cm.) W x 47 $\frac{1}{8}$ " (120 cm.) H x 15" (38 cm.) D.

**Weight:**

166 lbs. (75 Kg.)

V9 TONE P.C. BOARD  
(VIEWED FROM COPPER SIDE)

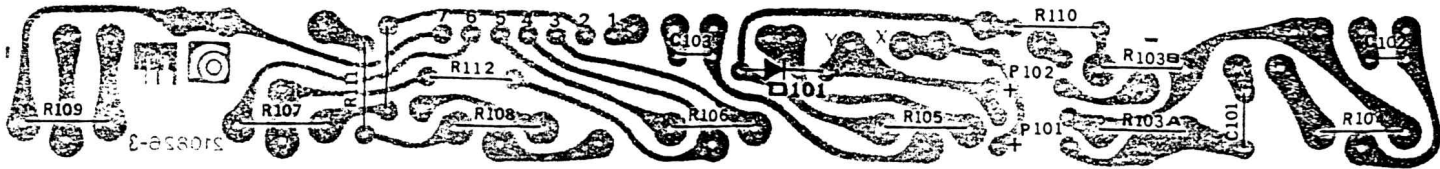

DISASSEMBLY INSTRUCTIONS

**BACK PANEL** a. Release perforated back panel by means of 18 screws.

b. Un-plug the fan before completely removing the back cover.

**POWER CHASSIS** a. Turn chassis on its side.

b. Remove 8 screws or bolts from the bottom of the cabinet.

c. Remove pre-amp wire harness by disconnecting plastic plug.

d. Return cabinet to its normal position and remove power chassis.

**PRE-AMP** a. Remove the 4 screws from the inside of head cabinet.

b. Push pre-amp forward from inside of head cabinet.

**BAFFLE**

1. On older models the baffle is removable only by un-screwing the nuts from the single screws on either side of the baffle. The baffle is then removable if a slight tap is given from the inside to release the plastic head lock.

2. On new models the baffle is removable without removing the back panel. Use a long rod and tap the baffle free from the headlock retainers. Gain access from the rear of the cabinet by using the space available through the cooling fan blades. The removal of the baffle will enable the bias to be adjusted without the necessity of disassembling the entire head cabinet.

CALIBRATION PROCEDURE

1. Connect a 4 ohm 330W minimum load to speaker terminals.

2. Output stage bias current adjustment. (The bias can be adjusted by removing the head cabinet baffle. Use a long rod and tap the baffle free from the headlock retainers. Gain access from the rear of the cabinet by using the space available through the cooling fan blades.)

a. Adjust VR1 for 0.072 VDC between K1 and ground.

b. Adjust VR2 for  $0 \pm 0.01$  VDC between K1 and K2.

3. Phase inverter balance control adjustment.

a. Harmonic distortion meter method — Drive amplifier to 25 Volts R.M.S. out at 40 Hz. and connect distortion meter to load resistor. Adjust VR3 for minimum distortion.

b. Volt meter method — Adjust output as in step 3-A and conn D.C. volt meter between testing points K1 & K2, adjust VR3 for zero  $\pm .01$  volts.

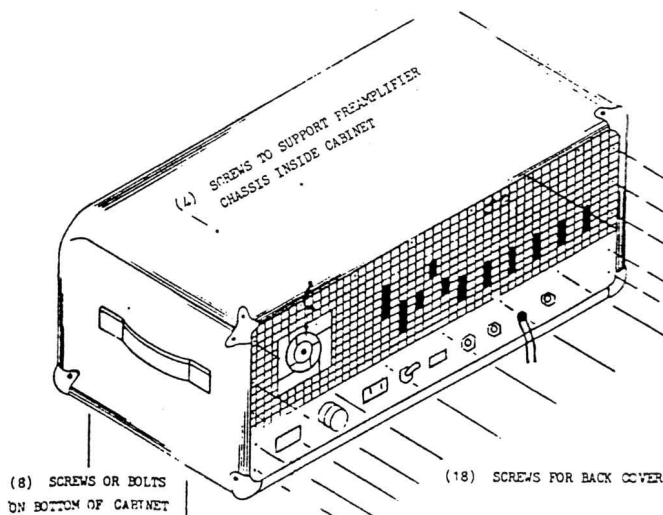

Continues.

V9 POWER AMP P.C. BOARD  
(VIEWED FROM COPPER SIDE)

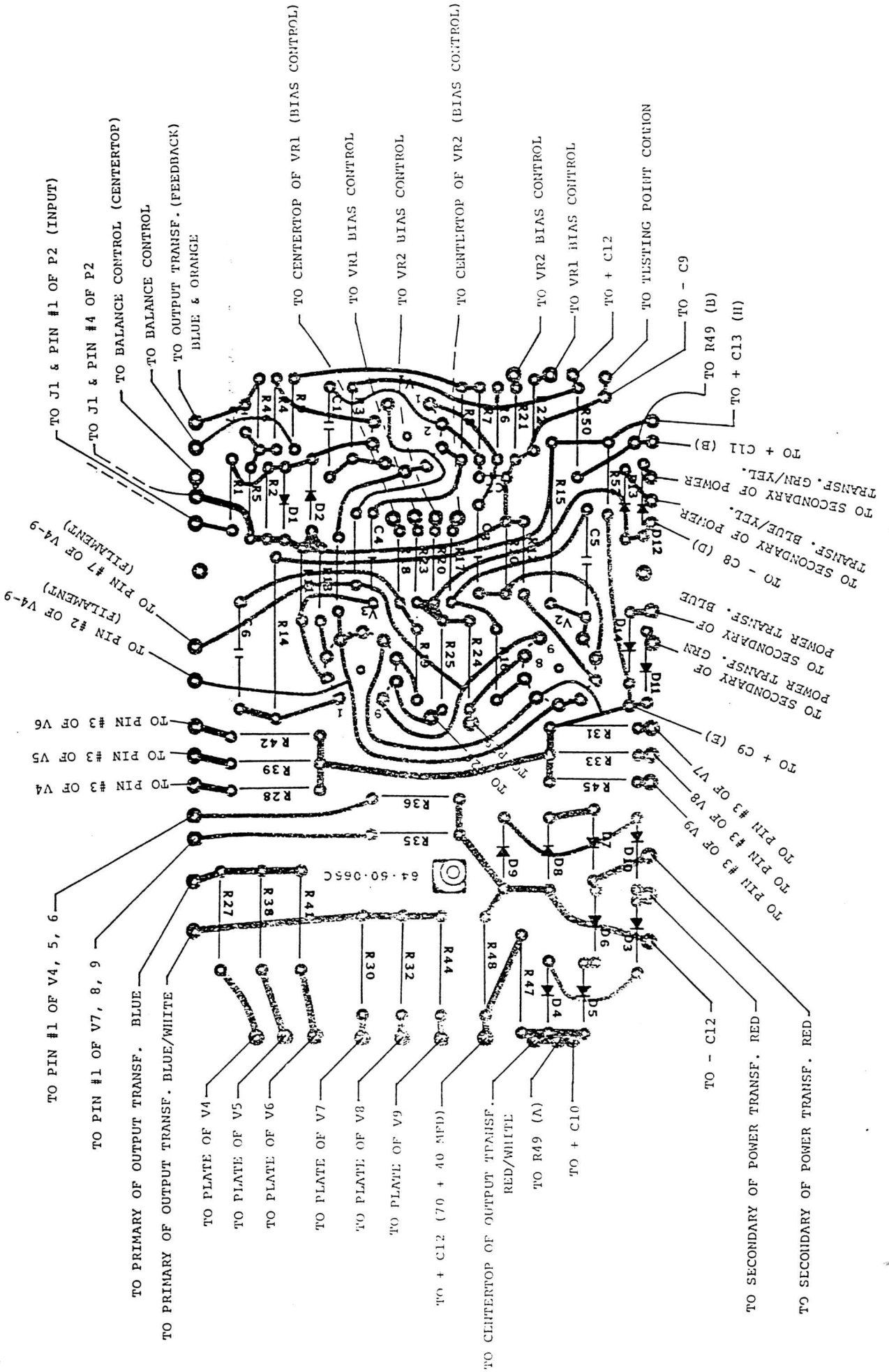

MODEL V9 POWER AMPLIFIER SCHEMATIC DIAGRAM (REV. 1)

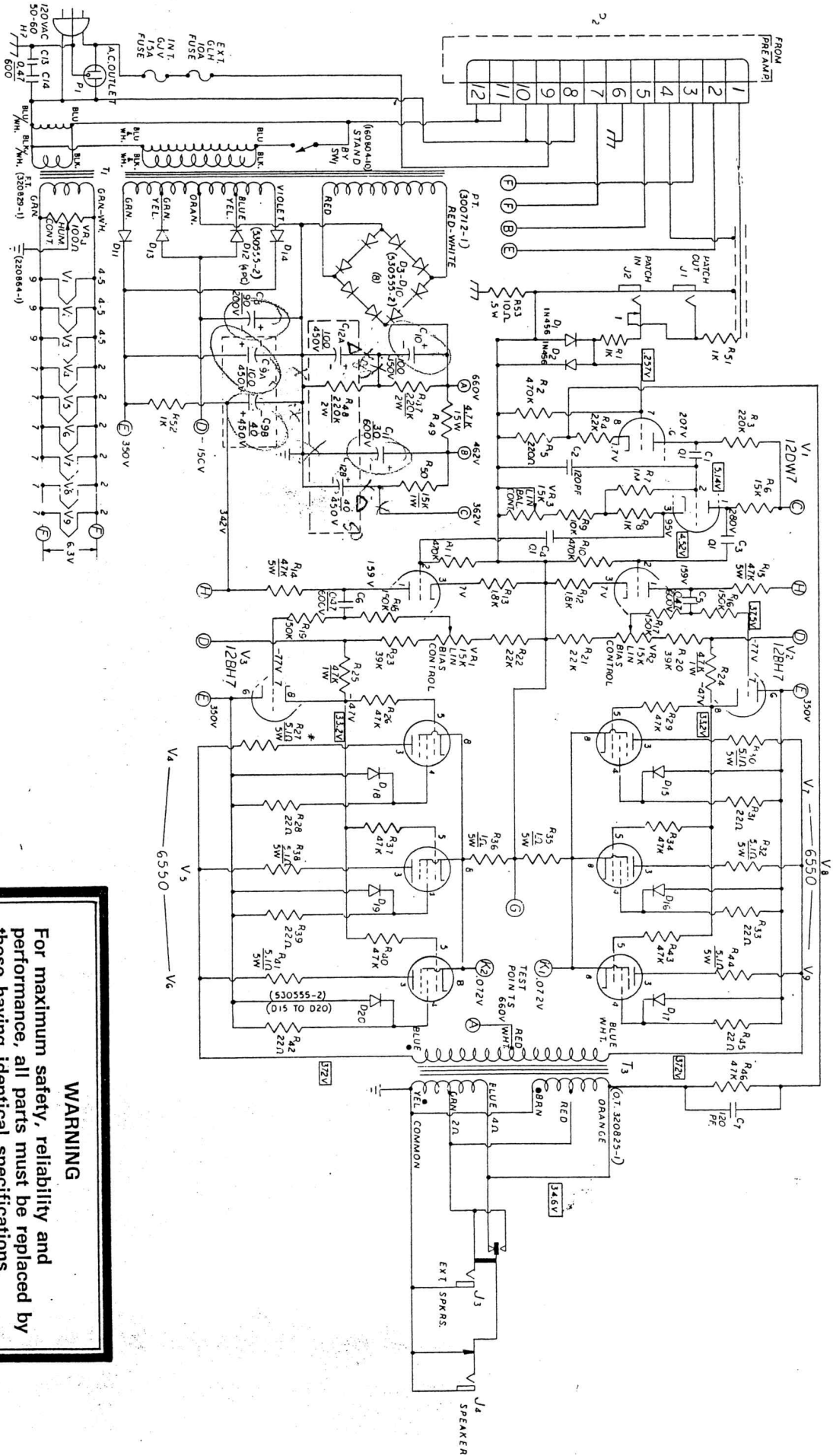

WARNING

For maximum safety, reliability and performance, all parts must be replaced by those having identical specifications. Under no circumstances may the original design be modified or altered without permission from the Ampex Company.

MODEL V9 PREAMP SCHEMATIC DIAGRAM (REV. A)

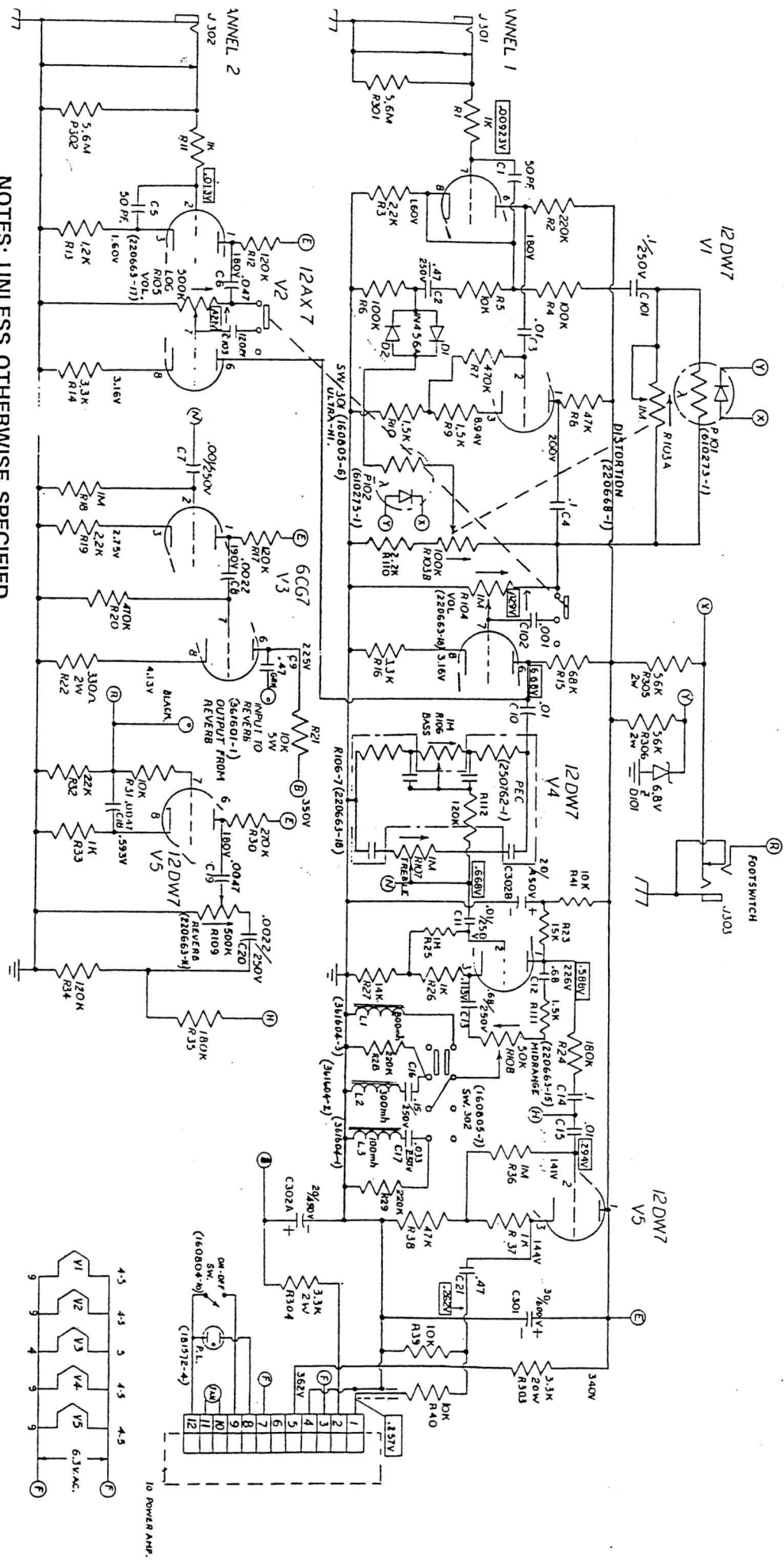

NOTES: UNLESS OTHERWISE SPECIFIED

1. Capacitance values are in microfarads, 10%, 400V.
2. Resistors are 1/2W, 10%, composition.
3. DC voltages with no signal applied using a 20,000 ohm/volt voltmeter.
4. DC voltages for V1, in the power amplifier are approximate and may vary with application.
5. When connector P2 is disconnected voltage at point "B" will rise to 600 volt.
6. Typical AC voltages are shown in boxes. Taken with tone controls at mid position and rocker switches to the left.
7. Actual circuit may vary slightly due to normal production changes.

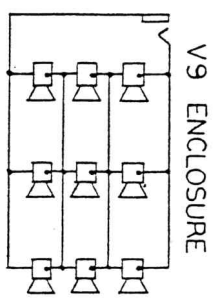
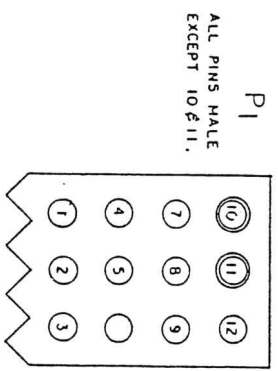

(9) 5.3 OHM SPEAKERS (580167-1)  
TOTAL NOMINAL IMPEDANCE 4 OHMS