



BA115HP

BA210

Bassamp Cube

BA115HP



BA210



User's Guide



TABLE OF CONTENTS:

Important Safeguards and Precautions3

The Top Panel4,5

The Electronic Tuner6

System Block Diagram7

Technical Specificationsback cover

 CAUTION RISK OF ELECTRIC SHOCK DO NOT OPEN	 PRECAUCION RIESGO DE CORRIENTAZO NO ABRA	 ATTENTION RISQUE D'ELECTROCUTION NE PAS OUVRIR
<small>WARNING: TO REDUCE THE RISK OF FIRE OR ELECTRIC SHOCK, DO NOT EXPOSE THIS APPARATUS TO RAIN OR MOISTURE. TO REDUCE THE RISK OF ELECTRIC SHOCK, DO NOT REMOVE COVER. NO USER-SERVICEABLE PARTS INSIDE. REFER SERVICING TO QUALIFIED SERVICE PERSONNEL.</small>	<small>PRECAUCION: PARA REDUCIR EL RIESGO DE INCENDIOS O DESCARGAS ELECTRICAS, NO PERMITA QUE ESTE APARATO QUEDA EXPUESTO A LA LLUVIA O LA HUMEDAD. PARA DISMINUIR EL RIESGO DE CORRIENTAZO, NO ABRA LA CUBIERTA. NO HAY PIEZAS ADETRON QUE EL USUARIO PUEDE REPARAR DE JE TODO MANTENIMIENTO A LOS TECNICOS CALIFICADOS.</small>	<small>ATTENTION: PROTEGEZ CET APPAREIL DE LA PLUIE ET DE L'HUMIDITE AFIN D'EVITER TOUT RISQUE D'INCENDIE OU D'ELECTROCUTION. POUR REDUIRE D'ELECTROCUTION NE PAS ENLEVER LE COUVERCLE. AUCUNE PIECE INTERNE N'EST REPARABLE PAR L'UTILISATEUR. POUR TOUTE REPARATION, S'ADRESSER A UN TECHNICIEN QUALIFIE.</small>

IMPORTANT SAFETY INSTRUCTIONS

- READ, FOLLOW, HEED, AND KEEP ALL INSTRUCTIONS AND WARNINGS.
- DO NOT OPERATE NEAR ANY HEAT SOURCE AND DO NOT BLOCK ANY VENTILATION OPENINGS ON THIS APPARATUS. FOR PROPER OPERATION, THIS UNIT REQUIRES 3" (75mm) OF WELL VENTILATED SPACE AROUND HEATSINKS AND OTHER AIR FLOW PROVISIONS IN THE CABINET.
- DO NOT USE THIS APPARATUS NEAR SPLASHING, FALLING, SPRAYING, OR STANDING LIQUIDS.
- CLEAN ONLY WITH LINT-FREE DAMP CLOTH AND DO NOT USE CLEANING AGENTS.
- ONLY CONNECT POWER CORD TO A POLARIZED, SAFETY GROUNDED OUTLET WIRED TO CURRENT ELECTRICAL CODES AND COMPATIBLE WITH VOLTAGE, POWER, AND FREQUENCY REQUIREMENTS STATED ON THE REAR PANEL OF THE APPARATUS.
- PROTECT THE POWER CORD FROM DAMAGE DUE TO BEING WALKED ON, PINCHED, OR STRAINED.
- UNPLUG THE APPARATUS DURING LIGHTNING STORMS OR WHEN UNUSED FOR LONG PERIODS OF TIME.
- ONLY USE ATTACHMENTS, ACCESSORIES, STANDS, OR BRACKETS SPECIFIED BY THE MANUFACTURER FOR SAFE OPERATION AND TO AVOID INJURY.
- WARNING: TO REDUCE THE RISK OF ELECTRIC SHOCK OR FIRE, DO NOT EXPOSE THIS UNIT TO RAIN OR MOISTURE..
- SERVICE MUST BE PERFORMED BY QUALIFIED PERSONNEL.
- OUR AMPLIFIERS ARE CAPABLE OF PRODUCING HIGH SOUND PRESSURE LEVELS. CONTINUED EXPOSURE TO HIGH SOUND PRESSURE LEVELS CAN CAUSE PERMANENT HEARING IMPAIRMENT OR LOSS. USER CAUTION IS ADVISED AND EAR PROTECTION IS RECOMMENDED IF UNIT IS OPERATED AT HIGH VOLUME.



EXPLANATION OF GRAPHICAL SYMBOLS:

EXPLICACION DE SIMBOLOS GRAFICOS:

EXPLICATION DES SYMBOLES GRAPHIQUES:



= "DANGEROUS VOLTAGE"
 = "VOLTAJE PELIGROSO"
 = "DANGER HAUTE TENSION"



"IT IS NECESSARY FOR THE USER TO REFER TO THE INSTRUCTION MANUAL"
 "ES NECESARIO QUE EL USUARIO SE REFERIA AL MANUAL DE INSTRUCCIONES."
 "REFERREZ-VOUS AU MANUAL D'UTILISATION"



IMPORTANT SAFEGUARDS AND PRECAUTIONS:

All Ampeg products are designed for continuous safe operation, as long as common sense is used and steps are taken to help avoid certain problems. Abiding by the following rules can help prevent damage to your amplifier, yourself and others.

- The amplifier is equipped with a three-pronged AC power cord. To reduce the risk of electrical shock, **NEVER** remove or otherwise attempt to defeat the ground pin of the power cord.
- Connect the amplifier **ONLY** to a properly grounded AC outlet of the proper voltage for your amp.
- Avoid sudden temperature extremes, rain and moisture. Also, avoid sudden and intense impact. (If the unit has been subjected to any of the preceding abuses, have it looked at by an authorized service center.)
- **NEVER** set the amplifier on a support that might give out under its weight.
- Always keep the total speaker impedance at or above the rated load.
- Unplug the amplifier before cleaning it. **NEVER** spray liquid cleaners onto the amplifier. Wipe it with a slightly dampened, lint-free cloth to remove dirt and film.
- Do not use the amplifier if it has sustained damage to the chassis, controls, or power cord. Refer the unit to an authorized service center for inspection.
- Amplifiers capable of producing high volume levels are also capable of inflicting permanent hearing loss or damage, if the exposure to such levels is prolonged. Such damage is progressive and irreversible!



THE TOP PANEL:

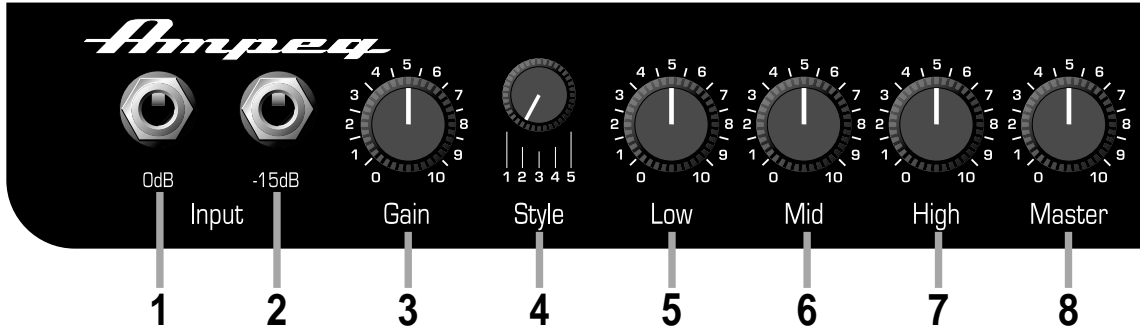

1. 0dB INPUT: Connect your “passive” bass guitar here using a shielded instrument cable. This input is not padded and is best suited for basses without active electronics.

2. -15dB INPUT: Connect your “active” bass here using a shielded instrument cable. This input is padded 15dB and is best suited for basses with active electronics and/or “hot” pickups.

3. GAIN: Use this control in conjunction with your instrument’s volume controls to adjust the level of the signal sent to the preamp.

4. STYLE: This five-position switch is used to control the tone of the amplifier. Experiment with the Style and other eq controls (#5,6,7) for the results which suit you best. The settings of the style control are as follows:

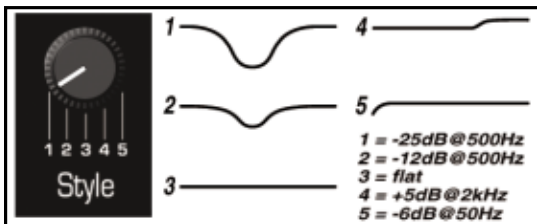

5. LOW: This control is used in conjunction with the style control to adjust the low frequency level of the amplifier.

6. MID: This control is used in conjunction with the style control to adjust the midrange level of the amplifier.

7. HIGH: This control is used in conjunction with the style control to adjust the high frequency level of the amplifier.

8. MASTER: Use this control to adjust the level of the output signal from the amplifier. This control also adjusts the signal level of the CD Inputs (#10), the Headphones jack (#12) and the Line Out jack (#13).

9. MUTE: This switch, when depressed, mutes the output signal, the Line Out signal, and the Headphones signal. This allows silent tuning and switching of instruments while the amplifier is still on. The CD inputs remain active when the Mute switch is depressed.

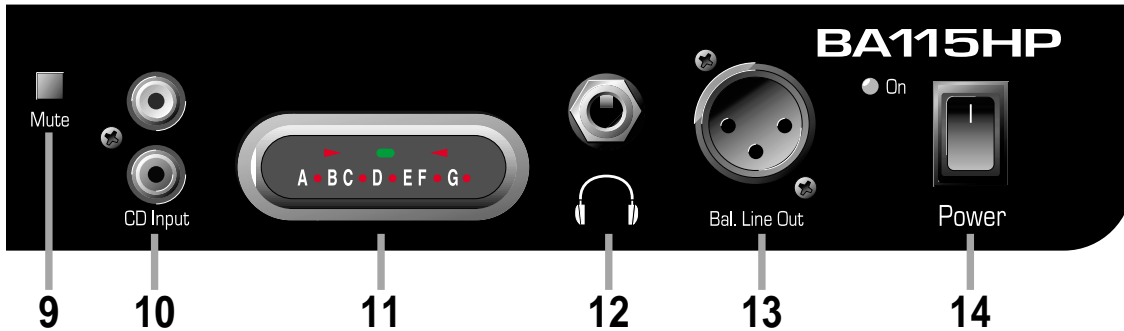

10. CD INPUT: Use these RCA jacks to connect the line level (or headphones) output of a CD player, tape deck or rhythm machine to the amplifier. The inputs to these jacks are summed into a mono signal which is fed into the BA115HP/BA210's power amplifier. The signal level from these jacks is adjusted by the amplifier's Master control (#8). If the signal from the source connected to these jacks is too strong, use the output level control on the source to adjust the signal to obtain the proper level for a good mix.

11. TUNER: Use this electronic tuner to tune your instrument. A complete description of the tuner is located on page 6.

12. HEADPHONES: Use this jack to listen to the amplifier through a pair of stereo headphones. The internal speaker is disconnected when the headphones jack is used.

13. BAL. LINE OUT: This jack supplies a post-eq, balanced line level signal for connecting to a house sound board, recording unit or external amplifier.

14. POWER: Use this switch to turn the amplifier on or off. The adjacent LED will illuminate when the amplifier is turned on.

15. AC LINE CORD: (rear panel, not shown) This grounded power cord is to be plugged into a grounded power outlet, wired to current electric codes and compatible with voltage, power, and frequency requirements stated on the rear panel. **Do not attempt to defeat the safety ground connection.**

16. HF LEVEL CONTROL: (cabinet back, not shown): Use this control to adjust the output level of the high frequency driver. With the control fully counter clockwise, there is no output from the high frequency driver. The high frequency driver output increases as you rotate the control clockwise.



THE ELECTRONIC TUNER:

The BA115HP/BA210 incorporate an active electronic tuner, built into the control panel. The electronic tuner is active whenever the amplifier is turned on, providing constant, “real-time” tuning. The bottom row of LEDs indicate which note (string) is being tuned. The top row of LEDs provides directional queues to facilitate quick and precise tuning of your instrument. The indicated note (string) is properly tuned when only the center LED is illuminated

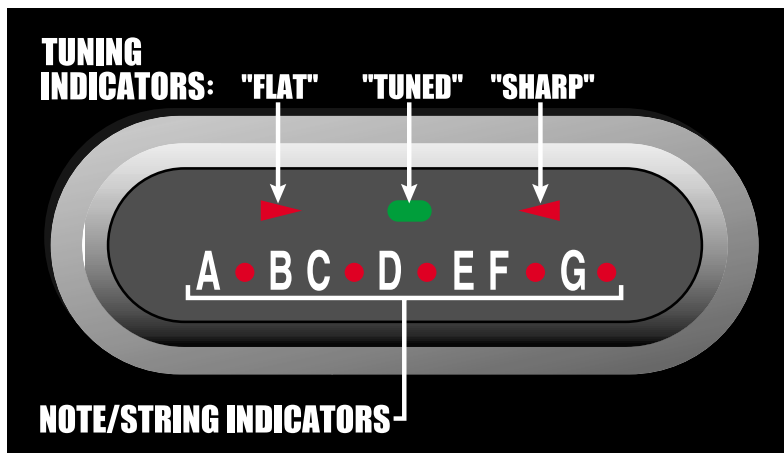



Ampeg BA115HP/BA210 Bassamp Cube

SYSTEM BLOCK DIAGRAM:

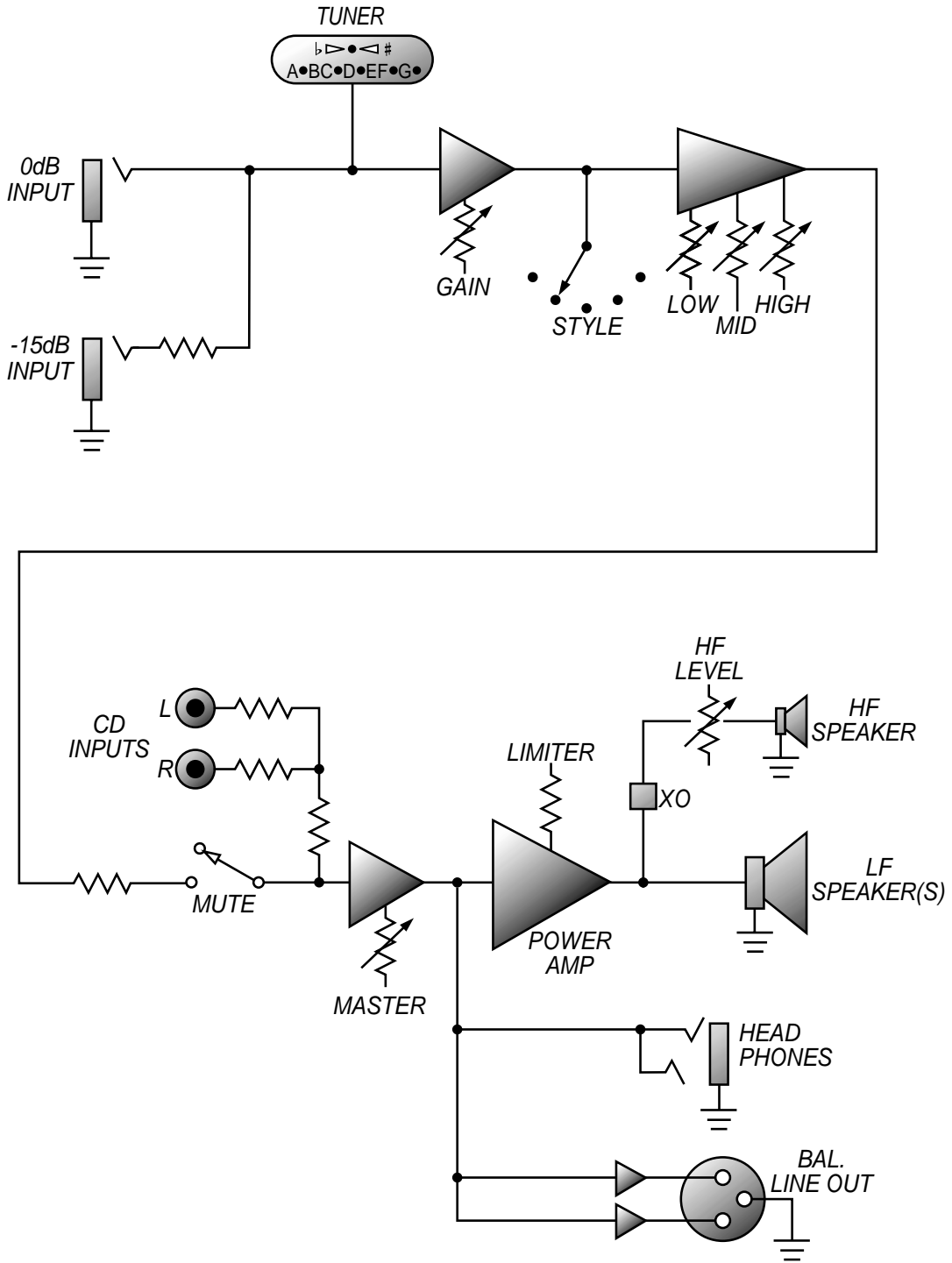

BA115HP/BA210

Bassamp Cube

TECHNICAL SPECIFICATIONS:

OUTPUT POWER RATING	220 Watts at 4 ohms @5% THD
MAX INPUT LEVELS	0dB Input: 2.00V RMS -15dB Input: 8.00V RMS CD Input: 7.75V RMS
LINE OUT LEVEL	1.78V RMS
HEADPHONE OUT LEVEL	900mV RMS
GAIN	46dB (input to speaker out, tones @5)
STYLE	1 = -25dB @500Hz 2 = -12dB @500Hz 3 = flat 4 = +5dB @2kHz and above 5 = -6dB @50Hz and below
LOW	40dB range @50Hz
MID	30dB range @500Hz
HIGH	40dB range @10kHz
SPEAKER SPECS	BA115HP: (1) 15", 250W, 4 ohm, 2.5" voice coil dia, 56 oz. magnet (1) 1" compression driver BA210: (2) 10", 150W, 8 ohm, 2" voice coil dia, 30 oz. magnet (1) 1" compression driver
POWER REQUIREMENTS	120VAC, 60Hz, 320VA 100/115VAC, 50/60Hz, 320VA 230VAC, 50/60Hz, 320VA
SIZE AND WEIGHT	21" W x 21" H x 15-1/2" D; 86 lbs.

Ampeg – The Power of Bass

CAUTION: THIS SPEAKER IS CAPABLE OF PRODUCING HIGH SOUND PRESSURE LEVELS. CONTINUED EXPOSURE TO HIGH SOUND PRESSURE LEVELS CAN CAUSE PERMANENT HEARING IMPAIRMENT OR LOSS. USER CAUTION IS ADVISED, AND EAR PROTECTION RECOMMENDED IF UNIT IS OPERATED AT HIGH VOLUME.



www.ampeg.com

Ampeg continually develops new products, as well as improves existing ones. For this reason, the specifications and information in this manual are subject to change without notice.



47-683-01 • 012203