



BA-210SP

Bassamp Cube
with
Digital Effects





TABLE OF CONTENTS:

Important Safeguards and Precautions3

The Top Panel4,5

The Digital Effects6

Programming the Footswitch7

System Block Diagram7

Technical Specificationsback cover

This equipment has been tested and found to comply with the limits for a Class B digital device, pursuant to part 15 of the FCC Rules. These limits are designed to provide reasonable protection against harmful interference in a residential installation. This equipment generates, uses and can radiate radio frequency energy and, if not installed and used in accordance with the instructions, may cause harmful interference to radio communications. However, there is no guarantee that interference will not occur in a particular installation. If this equipment does cause harmful interference to radio or television reception, which can be determined by turning the equipment off and on, the user is encouraged to try to correct the interference by one or more of the following measures:

- Reorient or relocate the receiving antenna.
- Increase the separation between the equipment and the receiver.
- Connect the equipment into an outlet on a circuit different from that to which the receiver is connected.
- Consult the dealer or an experienced radio/TV technician for help.

Changes or modifications to this device not expressly approved by SLM Electronics could void the user's authority to operate the equipment under FCC rules.





<u>Declaration of Conformity</u>	
Manufacturer's Name:	SLM Electronics
Corporate Headquarters:	1901 Congressional Drive, St. Louis, Missouri 63146
Primary Production Facility:	700 Hwy 202 W, Yellville, Arkansas, 72687
Product Type:	Audio Amplifier
Products meet the regulations for compliance marking under:	
	ETL standards UL6500, UL60065, or UL813
	CSA standards E60065 or C22.2 No.1-M90
	CE safety standard EN60065
	CE EMC standards EN55103 or EN55013 and EN61000
	C-tick designation Level 2, ABN #56748810738, ARBN# N222
	KETI standard K60065 (limited model approval)
Compliance Support Contact: SLM Electronics, Attn: R&D Compliance Engineer 1901 Congressional Drive, St Louis, Missouri, 63146 • Tel.: 314-569-0141, Fax: 314-569-0175	



IMPORTANT SAFEGUARDS AND PRECAUTIONS:

All Ampeg products are designed for continuous safe operation. Abiding by the following rules can help prevent damage to your amplifier, yourself and others.

- The amplifier is equipped with a three-pronged AC power cord. To reduce the risk of electrical shock, **NEVER** remove or otherwise attempt to defeat the ground pin of the power cord.
- Connect the amplifier **ONLY** to a properly grounded AC outlet of the proper voltage for your amp.
- Avoid sudden temperature extremes, rain and moisture. Also, avoid sudden and intense impact. (If the unit has been subjected to any of the preceding abuses, have it looked at by an authorized service center.)
- Do not expose the unit to splashing or dripping liquid. Do not place liquid filled objects on the unit.
- **NEVER** set the amplifier on a support that will not bear its weight.
- Always keep the total speaker impedance at or above the rated load.
- Unplug the amplifier before cleaning it. **NEVER** spray liquid cleaners onto the amplifier. Wipe it with a slightly dampened, lint-free cloth to remove dirt and film.
- **DO NOT** use the amplifier if it has sustained damage to the chassis, controls, or power cord. Refer the unit to an authorized service center for inspection.
- Prolonged exposure to high volume levels may cause permanent hearing loss or damage. Such damage is progressive and irreversible!

 CAUTION RISK OF ELECTRIC SHOCK DO NOT OPEN	 PRECAUCION RIESGO DE CORRIENTAZO NO ABRA	 ATTENTION RISQUE D'ELECTROCUTION NE PAS OUVRIR
WARNING: TO REDUCE THE RISK OF FIRE OR ELECTRIC SHOCK, DO NOT EXPOSE THIS APPARATUS TO RAIN OR MOISTURE. TO REDUCE THE RISK OF ELECTRIC SHOCK, DO NOT REMOVE COVER. NO USER-SERVICEABLE PARTS INSIDE. REFER SERVICING TO QUALIFIED SERVICE PERSONNEL.	PRECAUCION: PARA REDUCIR EL RIESGO DE INCENDIOS O DESCARGAS ELECTRICAS, NO PERMITA QUE ESTE APARATO QUEDE EXPUESTO A LA LLUVIA O LA HUMEDAD. PARA DISMINUIR EL RIESGO DE CORRIENTAZO, NO ABRA LA CUBIERTA. NO HAY PIEZAS ADEENTRO QUE EL USUARIO PUEDE REPARAR DEJE TODO MANTENIMIENTO A LOS TECNICOS CALIFICADOS.	ATTENTION: PROTEGEZ CET APPAREIL DE LA PLUIE ET DE L'HUMIDITE AFIN D'EVITER TOUT RISQUE D'INCENDIE OU D'ELECTROCUTION. POUR REDUIRE D'ELECTROCUTION NE PAS ENLEVER LE COUVERCLE. AUCUNE PIECE INTERNE N'EST REPARABLE PAR L'UTILISATEUR. POUR TOUTE REPARATION, S'ADRESSER A UN TECHNICIEN QUALIFIE.
IMPORTANT SAFETY INSTRUCTIONS		
<ul style="list-style-type: none"> • READ, FOLLOW, HEED, AND KEEP ALL INSTRUCTIONS AND WARNINGS. • DO NOT OPERATE NEAR ANY HEAT SOURCE AND DO NOT BLOCK ANY VENTILATION OPENINGS ON THIS APPARATUS. FOR PROPER OPERATION, THIS UNIT REQUIRES 3" (75mm) OF WELL VENTILATED SPACE AROUND HEATSINKS AND OTHER AIR FLOW PROVISIONS IN THE CABINET. • DO NOT USE THIS APPARATUS NEAR SPLASHING, FALLING, SPRAYING, OR STANDING LIQUIDS. • CLEAN ONLY WITH LINT-FREE DAMP CLOTH AND DO NOT USE CLEANING AGENTS. • ONLY CONNECT POWER CORD TO A POLARIZED, SAFETY GROUNDED OUTLET WIRED TO CURRENT ELECTRICAL CODES AND COMPATIBLE WITH VOLTAGE, POWER, AND FREQUENCY REQUIREMENTS STATED ON THE REAR PANEL OF THE APPARATUS. • PROTECT THE POWER CORD FROM DAMAGE DUE TO BEING WALKED ON, PINCHED, OR STRAINED. • UNPLUG THE APPARATUS DURING LIGHTNING STORMS OR WHEN UNUSED FOR LONG PERIODS OF TIME. • ONLY USE ATTACHMENTS, ACCESSORIES, STANDS, OR BRACKETS SPECIFIED BY THE MANUFACTURER FOR SAFE OPERATION AND TO AVOID INJURY. • WARNING: TO REDUCE THE RISK OF ELECTRIC SHOCK OR FIRE, DO NOT EXPOSE THIS UNIT TO RAIN OR MOISTURE. • SERVICE MUST BE PERFORMED BY QUALIFIED PERSONNEL. • OUR AMPLIFIERS ARE CAPABLE OF PRODUCING HIGH SOUND PRESSURE LEVELS. CONTINUED EXPOSURE TO HIGH SOUND PRESSURE LEVELS CAN CAUSE PERMANENT HEARING IMPAIRMENT OR LOSS. USER CAUTION IS ADVISED AND EAR PROTECTION IS RECOMMENDED IF UNIT IS OPERATED AT HIGH VOLUME. • WARNING: THIS UNIT REQUIRES A SAFETY GROUNDED OUTLET WIRED TO CURRENT ELECTRIC CODES HAVING THE LINE SUPPLY VOLTAGE, POWER, AND FREQUENCY IDENTIFIED ON THE REAR OF THE UNIT. THE OUTLET MUST REMAIN ACCESSIBLE TO DISCONNECT THE UNIT IF A FAULT SHOULD ARISE WHILE IN USE. THIS UNIT SHOULD BE UNPLUGGED WHEN NOT IN USE. 		
EXPLANATION OF GRAPHICAL SYMBOLS: EXPLICACION DE SIMBOLOS GRAFICOS: EXPLICATION DES SYMBOLES GRAPHIQUES:	 = "DANGEROUS VOLTAGE" "VOLTAJE PELIGROSO" "DANGER HAUTE TENSION"	 = "IT IS NECESSARY FOR THE USER TO REFER TO THE INSTRUCTION MANUAL" "ES NECESARIO QUE EL USUARIO SE REFIERA AL MANUAL DE INSTRUCCIONES." "REFERREZ-VOUS AU MANUAL D'UTILISATION"



THE TOP PANEL:

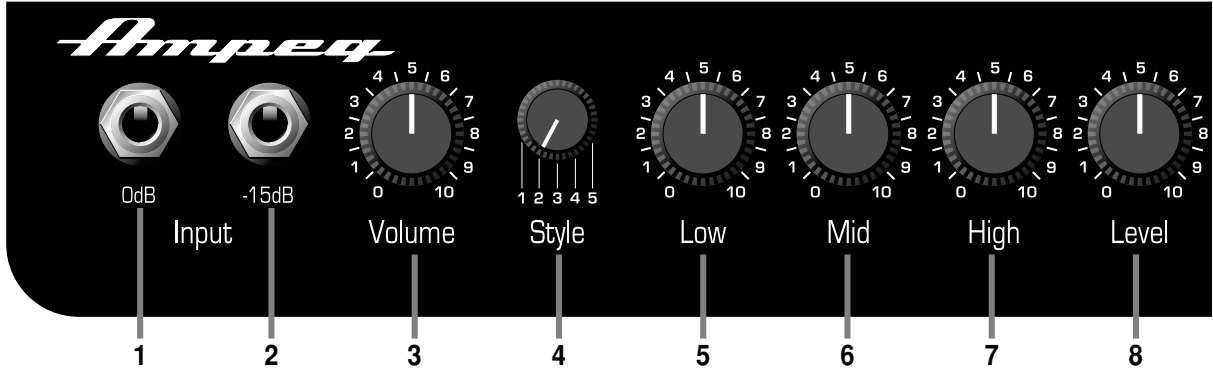

1. 0dB INPUT: Connect your “passive” bass guitar here using a shielded instrument cable. This input is not padded and is best suited for basses without active electronics.

2. -15dB INPUT: Connect your “active” bass here using a shielded instrument cable. This input is padded 15dB and is best suited for basses with active electronics and/or “hot” pickups.

3. VOLUME: Use this control in conjunction with your instrument’s volume controls to adjust the level of the signal sent to the pre-amp. For the best signal to noise ratio and maximum headroom, start with this control at 5 or greater.

4. STYLE: This five-position switch is used to control the tone of the amplifier. Experiment with the Style and other eq controls (#5,6,7) for the results which suit you best. The settings of the style control are as follows:

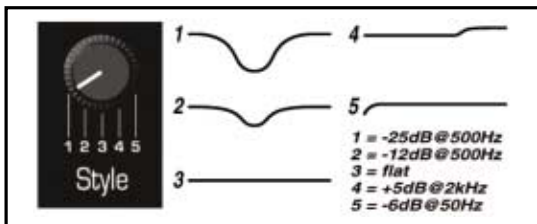

5. LOW: This control is used in conjunction with the style control to adjust the low frequency level of the amplifier.

6. MID: This control is used in conjunction with the style control to adjust the midrange level of the amplifier.

7. HIGH: This control is used in conjunction with the style control to adjust the high frequency level of the amplifier.

8. LEVEL: Use this control to adjust the level of the output signal from the amplifier. This control also adjusts the signal level of the CD Inputs (#12), the Headphones jack (#13) and the Line Out jack (#15).

9. EFFECTS SELECT: Use this control to select the desired digital effect. A listing of the effects is shown on page 6.

10. EFFECTS ADJUST: Use this control to adjust one of the parameters of the selected digital effect. A listing of the parameters for each of the effects is shown on page 6.

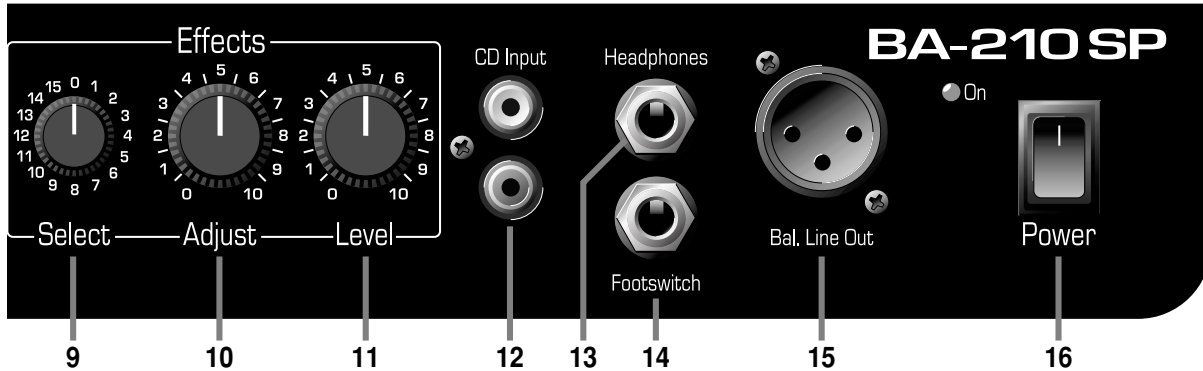

11. EFFECTS LEVEL: Use this control to adjust the level of the selected digital effect.

12. CD INPUT: Use these RCA jacks to connect the line level (or headphones) output of a CD player, tape deck or rhythm machine to the amplifier. The inputs to these jacks are summed into a mono signal which is fed into the BA210SP's power amplifier. The signal level from these jacks is adjusted by the amplifier's Level control (#8). If the signal from the source connected to these jacks is too strong, use the output level control on the source to adjust the signal to obtain the proper level for a good mix.

13. HEADPHONES: Use this jack to listen to the amplifier through a pair of stereo headphones. The internal speaker is disconnected when the headphones jack is used.

14. FOOTSWITCH: Use this jack to connect the supplied two button footswitch to the amplifier for remote control of the digital effects. For information on programming the footswitch, see page 7.

15. BAL. LINE OUT: This jack supplies a post-eq, balanced line level signal for connecting to a house sound board, recording unit or external amplifier.

16. POWER: Use this switch to turn the amplifier on or off. The adjacent LED will illuminate when the amplifier is turned on.

17. AC LINE CORD (rear panel, not shown): This heavy duty, grounded, three wire power cord is to be plugged into a safely-wired, grounded, 120 volt, 60 cycle AC power outlet. DO NOT attempt to defeat the ground connection of this cable! If your amplifier was purchased outside of the United States, see the unit's rear panel for its power and voltage ratings and follow the above guidelines.



THE DIGITAL EFFECTS:

The BA-210SP features 15 built-in digital effects designed especially for the bass. Use the Effects Select control to choose one of these effects. The numbers that circumscribe the control correspond to the “effects menu” below (and to the chart on the back of the amplifier). Each effect has a parameter which can be modified using the Adjust control. Use the Level control to mix in the desired amount of effect.

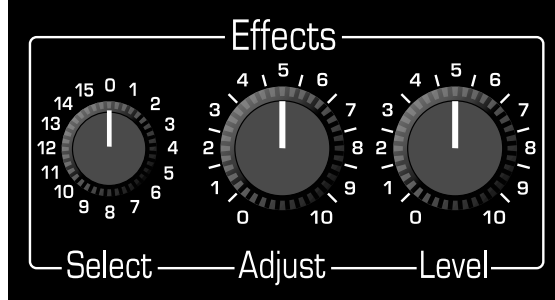

BA210SP DSP Section – top panel

EFFECTS MENU

#	DESCRIPTION	ADJUST
0	BYPASS - no effects	n/a
1	CHORUS - deep, timed based, full of movement	SPEED
2	FLANGE - the classic whoosh of a good flange	SPEED
3	PHASE SHIFTER - a 4-stage multiple-frequency phase shifter	SPEED
4	REVERB - adjustable from a tight room to a large hall	ROOM SIZE
5	OCTAVIDER - with a twist - smooth or with low growl	TONE
6	ECHO - multiple repeat echo	DELAY TIME
7	SLAPBACK - single repeat “slap”	DELAY TIME
8	FUNK WAH - the “quack” of a good envelope triggered filter	THRESHOLD
9	REVERSE WAH - envelope-triggered filter, swept high to low	THRESHOLD
10	CHORUS / ECHO / WAH - a “dreamy combination”	THRESHOLD
11	OCTAWAH - for when ya wanna get “really funky”	THRESHOLD
12	SVT - classic tube warmth, can get mild overdrive fatness	GAIN
13	SYNTH BASS 1 - a funky synthesized bass sound	THRESHOLD
14	SYNTH BASS 2 - an even funkier synthesized bass sound	THRESHOLD
15	SQUARE WAVE - heavily overdriven, smooth to sizzling	TONE



PROGRAMMING THE FOOTSWITCH:

The BA-115SP allows you to save four DSP settings by means of the two button footswitch supplied with the amplifier. Use the following steps to store and recall four DSP settings:

- Press the footswitch button until both LEDs are off – select an effect (bypass, “0”) – for reference, this shall be Preset A
- Press the #1 button on the footswitch (the #1 LED illuminates and Preset A is stored) - select another effect (chorus, “1”) and adjust to taste – for reference, this shall be Preset B
- Press the #2 button on the footswitch (the #2 LED illuminates and Preset B is stored) - select another effect (octawah, “11”) and adjust to taste – for reference, this shall be Preset C
- Press the #1 button on the footswitch again (the #1 LED turns off and Preset B is stored) - select another effect (SVT, “12”) and adjust to taste – for reference, this shall be Preset D
- Press the #2 button on the footswitch again (both LEDs are off and Preset D is stored) - Preset A is automatically recalled – without changing the setting of the Effects control. Selection of the effects is now controlled by the footswitch.

NOTE: The footswitch presets will be retained within the amplifier even after turning the amplifier off, until the above steps are repeated using different effects settings.

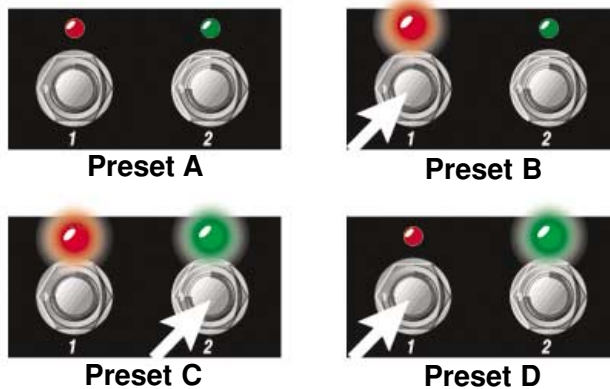

SYSTEM BLOCK DIAGRAM:

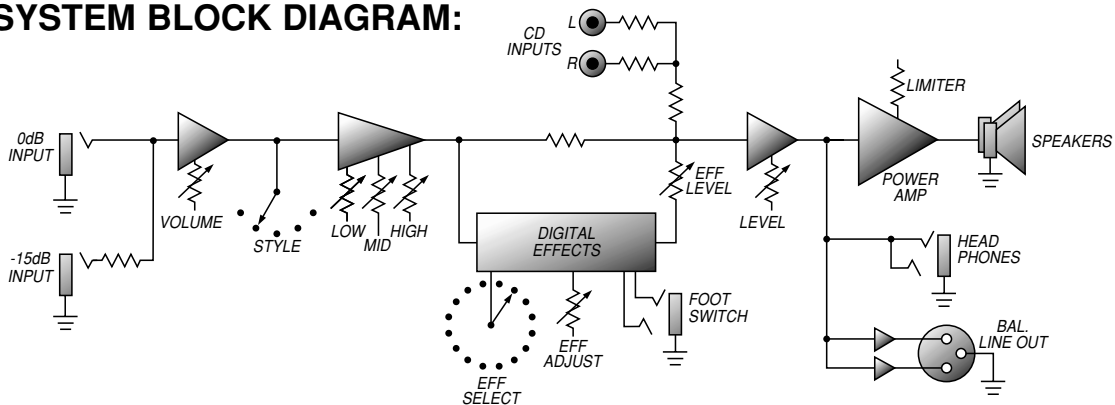

BA-210SP Bassamp Cube with Digital Effects

TECHNICAL SPECIFICATIONS:

OUTPUT POWER RATING	220 Watts at 4 ohms @5% THD
MAX INPUT LEVELS	0dB Input: 2.00V RMS -15dB Input: 8.00V RMS CD Input: 7.75V RMS
LINE OUT LEVEL	1.78V RMS
HEADPHONE OUT LEVEL	900mV RMS
GAIN	41dB (input to speaker out, tones @5)
STYLE	1 = -25dB @500Hz 2 = -12dB @500Hz 3 = flat 4 = +5dB @2kHz and above 5 = -6dB @50Hz and below
LOW	40dB range @50Hz
MID	30dB range @500Hz
HIGH	40dB range @10kHz
SPEAKER SPECS	(2) 10", 100 w, 8 ohm, 2" voice coil dia., 30oz. magnet Piezo tweeter
POWER REQUIREMENTS	120VAC, 60Hz, 320VA 100/115VAC, 50/60Hz, 320VA 230VAC, 50/60Hz, 320VA
SIZE AND WEIGHT	21" W x 21" H x 15-1/2" D; 86 lbs.

Ampeg – The Power of Bass

CAUTION: THIS SPEAKER IS CAPABLE OF PRODUCING HIGH SOUND PRESSURE LEVELS. CONTINUED EXPOSURE TO HIGH SOUND PRESSURE LEVELS CAN CAUSE PERMANENT HEARING IMPAIRMENT OR LOSS. USER CAUTION IS ADVISED, AND EAR PROTECTION RECOMMENDED IF UNIT IS OPERATED AT HIGH VOLUME.



www.ampeg.com

Made with Pride in the U.S.A. by Ampeg

Ampeg continually develops new products, as well as improves existing ones. For this reason, the specifications and information in this manual are subject to change without notice.

©2004 AMPEG, 1400 Ferguson Avenue, St. Louis, MO 63133 U.S.A.

47-308-02 • 121404

