

Ampeg®

Heritage
SVT-410HLF & SVT-810E
Bass Guitar Cabinets

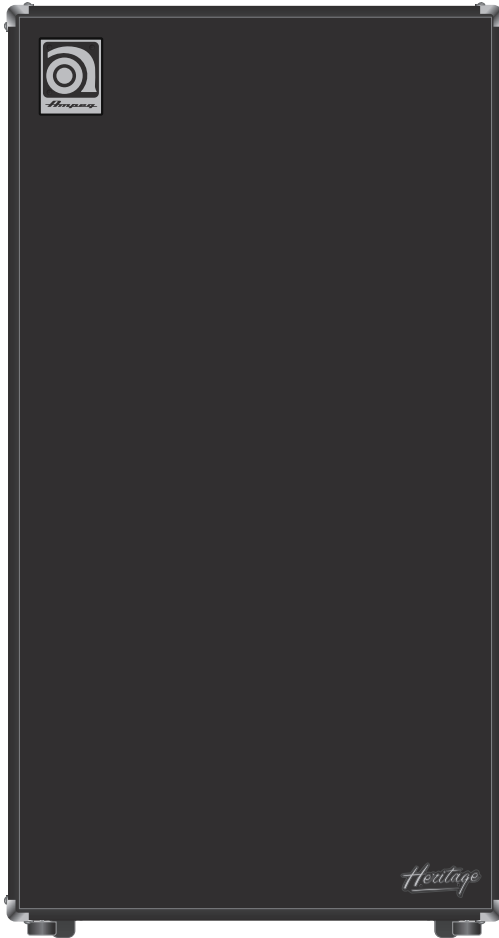

Owner's Manual

TABLE OF CONTENTS

What's in the Box	2
Introduction	2
Eminence Speakers	3
Impedance: The Golden Rule	3
SVT-410HLF Jackplate	4
SVT-410HLF Suggested Hookup Diagrams	5
Heritage SVT-410HLF Technical Specifications	7
SVT-810E Jackplate	8
SVT-810E Suggested Hookup Diagrams	9
Heritage SVT-810E Technical Specifications	11
Warranty and Support	12

What's in the Box

Heritage™ SVT®-410HLF or SVT-810E Speaker Cabinet, Quick Start Guide.

Introduction

Welcome to the world of Ampeg! Whether this is your first experience with Ampeg or you're a well-seasoned player who's been around the globe a few times with our gear, you are taking part in a piece of musical history. From here on out, nothing else will sound the same... everything else will pale in comparison. You are one of the lucky few to take part in a new chapter of an American legacy. Ampeg has come home! Each Heritage Series amplifier and cabinet is designed and assembled right here in the U.S.A. We've heard from bass players around the globe about their dedication and commitment to Ampeg and the Heritage Series is made specifically for those players—Just our way of saying thank you and letting you know that we heard you loud and clear.

Ampeg is the standard by which all others are measured. We've been pounding bass player's chests and audiences' booties for over 60 years now and we're not going to slow down anytime soon. From our early days of building "amplified pegs" for upright players, to building the world famous, stadium rattling, SVT amplifiers, Ampeg has been **the** choice for bassists, from touring professionals, to weekend warriors, and everyone in between. We were the first ones on the block listening and building gear for bass players. Heck, even our company's founding fathers were working, gigging players. When they weren't tinkering around the shop on new ideas, they were out in the clubs of New York earning their living. Not much has changed since then.

The average length of a hit song is 3 minutes and 40 seconds. We have been a part of most of those hits for over 60 years. Now that you own a piece of Ampeg history, we want to be a part of your next hit.

In order to get the most out of your new Ampeg speaker cabinet, please fully read this *Owner's Manual*, as well as the *Important Safety Instructions* included with your cabinet, before you begin playing.

And **thank you** for choosing Ampeg.

Eminence Speakers

There are some relationships that go hand in hand in the music business. When it comes to building amplifiers and cabinets, nothing is more well-suited than the relationship between Ampeg and Eminence® speakers. Ampeg commissioned Eminence decades ago to build one of the first 18" speakers used in an Ampeg amplifier. We've been calling on Eminence ever since to custom build speakers used in some of our most famous models. From the SVT-410HLF and stadium-rattling SVT-810E, to the latest Heritage and Pro Neo™ Series, Eminence is at the heart and soul of our most loved cabinets! It's no secret what goes into building a great cabinet: innovative designs, superb materials, and world class components.



Impedance: The Golden Rule

When it comes to tube amps, be sure that the output impedance of the amplifier matches the total impedance of the speaker cabinet or cabinets.

SVT-410HLF Jackplate

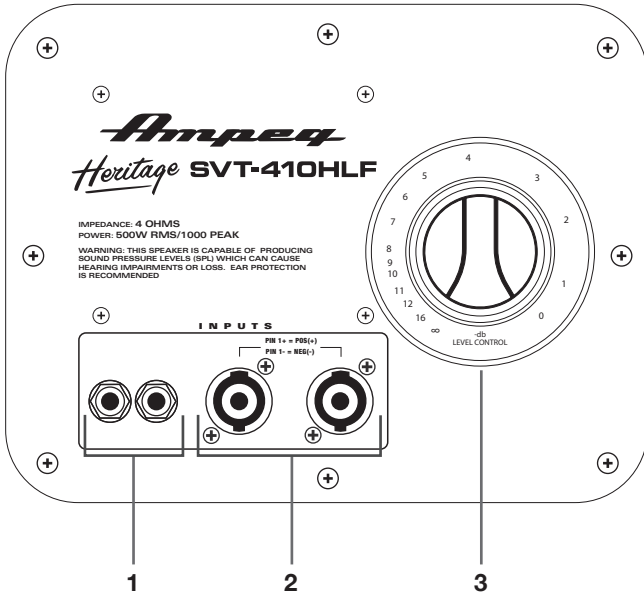

1. 1/4" Input / Output Jacks
2. Speakon® Input / Output Jacks
3. High Frequency Horn Level Control

Speakon to 1/4" Wiring Diagram

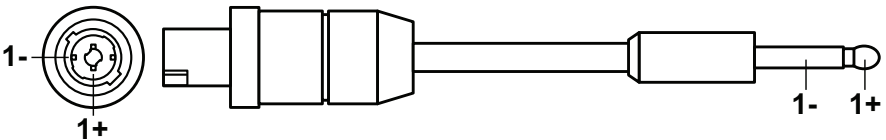

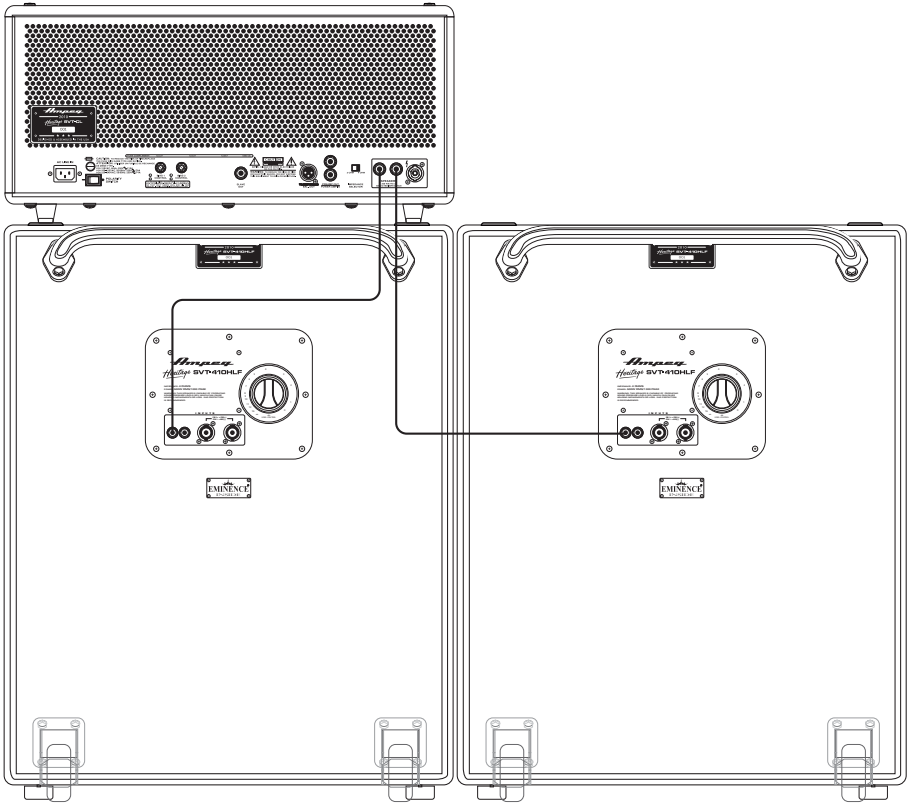
SVT-410HLF Suggested Hookup Diagrams**1**

In example 1 above, a speaker cable with 1/4" ends connects from one speaker output of the amplifier to the speaker input of the Ampeg Heritage SVT-410HLF cabinet. An additional cabinet may be connected by attaching another speaker cable from the remaining 1/4" speaker output of the amplifier to a speaker input of the next cabinet.

2

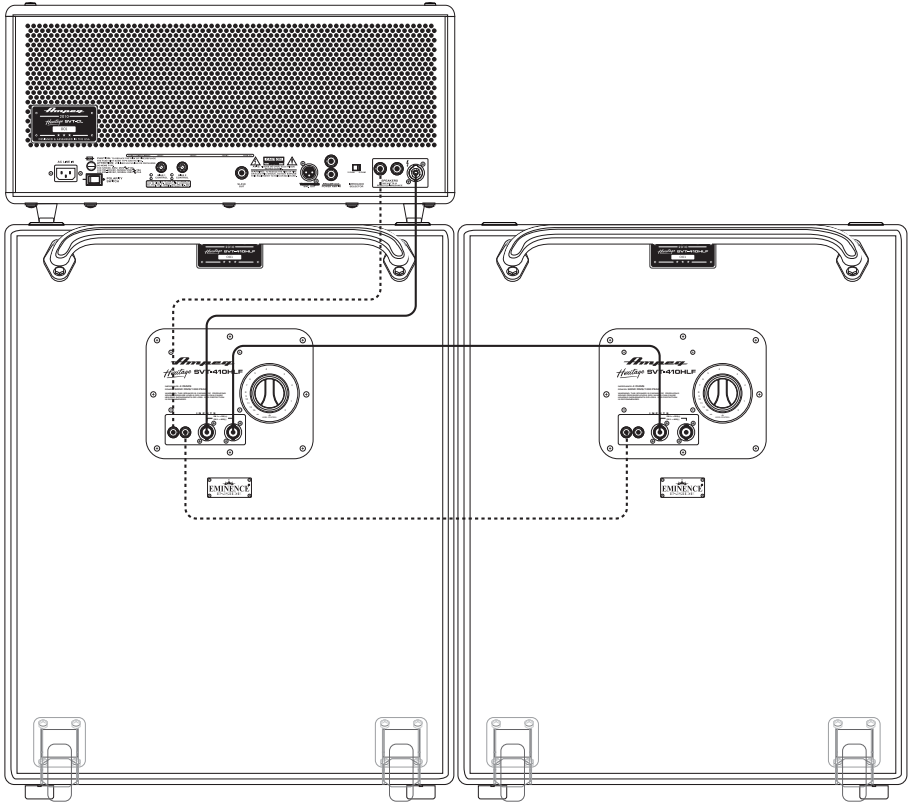

Example 2 above is not as common, but is great for daisy-chaining multiple cabinets. You may connect a speaker cable with 1/4" or Speakon ends from one speaker output of the amplifier to the speaker input of the Ampeg Heritage SVT-410HLF cabinet. An additional cabinet may be connected by attaching another speaker cable from an open jack (thru) to the input jack of the next cabinet. Multiple cabinets may be daisy-chained this way.

 **WARNING:** Always use good quality (non-shielded) speaker cables. Never use (shielded) instrument cables to connect speakers to an amplifier. Also, do not use both cable routes listed in example 2 above. Use one route or the other, but never both simultaneously!

Heritage SVT-410HLF Technical Specifications

Type	4x10 Bass Enclosure
Frequency Response (+/-3 dB)	48 Hz – 18 kHz
Usable Low Frequency (-10 dB)	28 Hz
RMS Power Handling	500 Watts
Peak Power Handling	1000 Watts
Impedance	4 Ω
Sensitivity	98 dB SPL 1W/1m
Maximum SPL	125 dB
Components	4 Custom Designed Eminence 125 Watt 10” speakers 1 Eminence HF Driver
Size (H x W x D)	24.0 in/610 mm (with feet) x 30.0 in/762 mm x 19.0 in/483 mm
Weight	76 lb/34.47 kg (approximately)

The Heritage SVT-410HLF is covered with a durable, fabric-backed vinyl material. Clean with a dry, lint-free cloth. Never spray cleaning agents on the Heritage SVT-410HLF. Avoid abrasive cleansers which would damage the finish.

Ampeg continually develops new products and improves upon existing ones. For this reason, the specifications and information in this manual are subject to change without notice.

SVT-810E Jackplate

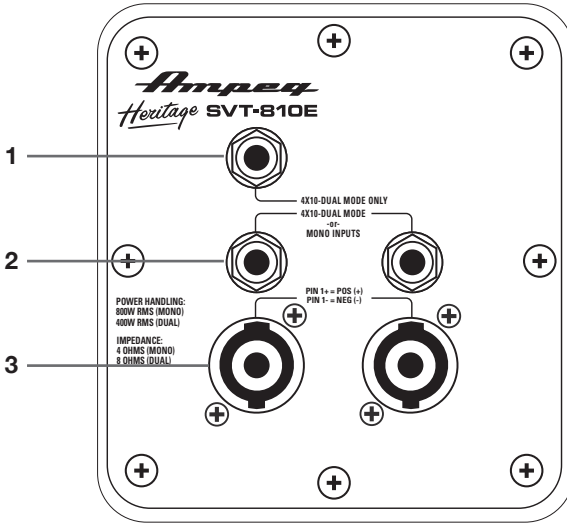

1. 1/4" Upper 4x10 Dual Mode Input Jack
2. 1/4" Lower 4x10 Dual Mode or Mono Mode Input / Output Jacks
3. Speakon Lower 4x10 Dual Mode or Mono Mode Input / Output Jacks

The cabinet operates in Dual Mode whenever a connector is inserted into the 1/4" Upper 4x10 Dual Mode input jack [1]. Otherwise, the cabinet operates in the single 8x10 Mono Mode.

Speakon to 1/4" Wiring Diagram

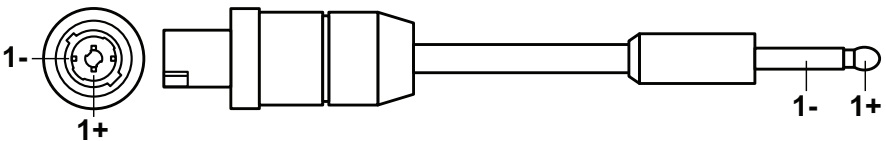

SVT-810E Suggested Hookup Diagrams

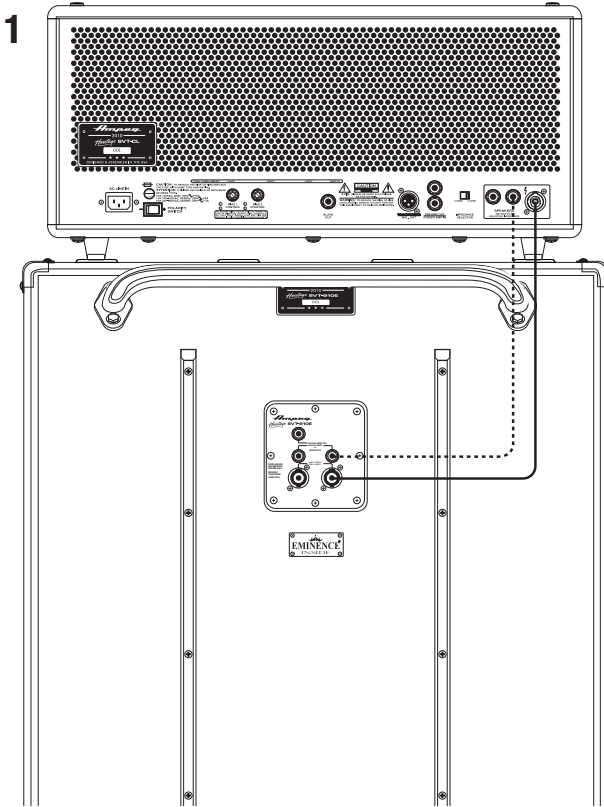

In the "Combined (mono)" example 1 above, a speaker cable with 1/4" or Speakon ends connects from the speaker output of the amplifier to one of the Lower 4x10 Dual Mode/ Mono Mode speaker inputs of the Ampeg Heritage SVT-810E cabinet. This configuration allows an amplifier to drive all 8x10 speakers.

 **WARNING:** Always use good quality (non-shielded) speaker cables. Never use (shielded) instrument cables to connect speakers to an amplifier. Also, do not use both cable routes in the example listed above. Use one route or the other, but never both simultaneously!

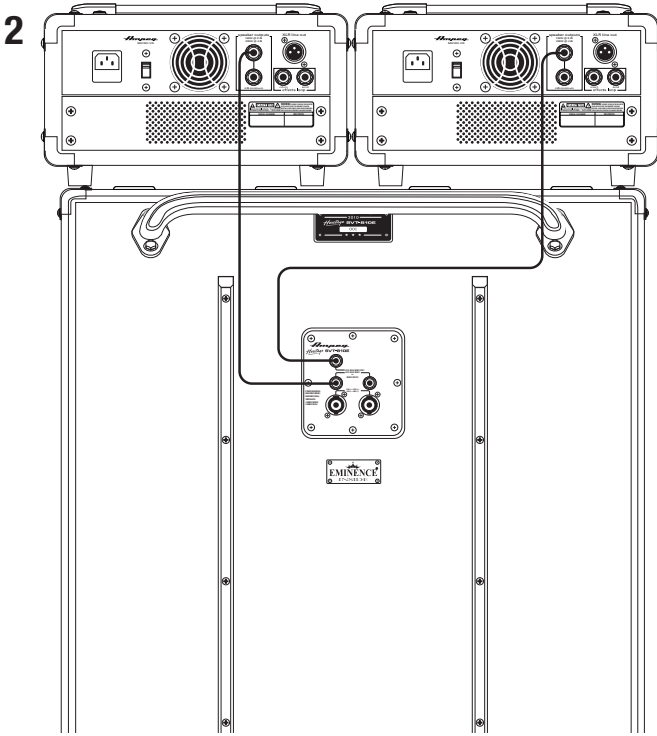

In the "Split (dual)" example **2** above, a speaker cable with 1/4" ends connects from the speaker output of the amplifier to the Upper 4x10 Dual Mode 1/4" input of the Ampeg Heritage SVT-810E cabinet. An additional speaker cable with 1/4" ends connects from the speaker output of another amplifier to the Lower 4x10 Dual Mode/Mono Mode 1/4" input. This configuration allows two amplifiers to separately drive each 4x10 section of the full cabinet.

 **WARNING:** Always use good quality (non-shielded) speaker cables. Never use (shielded) instrument cables to connect speakers to an amplifier.

Heritage SVT-810E Technical Specifications

Type	8x10 / Dual 4x10 Bass Enclosure
Frequency Response (+/-3 dB)	58 Hz – 5 kHz
Usable Low Frequency (-10 dB)	40 Hz
RMS Power Handling	Combined / Mono Mode: 800 Watts 8x10 Split / Dual Mode: 400 Watts each 4x10
Peak Power Handling	Combined / Mono Mode: 1600 Watts 8x10 Split / Dual Mode: 800 Watts each 4x10
Impedance	Combined / Mono Mode: 4 Ω 8x10 Split: 8 Ω each 4x10
Sensitivity	Combined / Mono Mode: 100 dB SPL 1W/1m
Maximum SPL	130 dB
Components	Eight Custom Designed, Eminence 100 Watt, 10" speakers
Size (H x W x D)	48.0 in/1219 mm (with feet) x 26.0 in/660 mm x 16.0 in/406 mm
Weight	137 lb/62.14 kg (approximately)

The Heritage SVT-810E is covered with a durable fabric-backed vinyl material. Clean with a dry, lint-free cloth. Never spray cleaning agents on the Heritage SVT-810E. Avoid abrasive cleansers which would damage the finish.

Ampeg continually develops new products and improves upon existing ones. For this reason, the specifications and information in this manual are subject to change without notice.

Warranty and Support

Visit WWW.AMPEG.COM to...

- (1) ...identify **WARRANTY** coverage provided in your local market. Please keep your sales receipt in a safe place.
- (2) ...**REGISTER** your product.
- (3) ...**CONTACT** Technical Support, or call 818-575-3600.

www.ameg.com
Yamaha Guitar Group, Inc.
26580 Agoura Road, Calabasas, CA 91302-1921 USA
Rev. A



© 2019 Yamaha Guitar Group, Inc. All rights reserved.

Ampeg, the Ampeg logo, Heritage, Pro Neo, and SVT are trademarks or registered trademarks of Yamaha Guitar Group, Inc. in the U.S. and/or other jurisdictions. Eminence and the Eminence logo are registered trademarks of Eminence Speaker, LLC. Speakon is a registered trademark of Neutrik AG Corporation.