

User's Guide

for the



Ampeg

BA500

Bass Amp Combo



Ampeg



TABLE OF CONTENTS

Introduction	3
Features	3
The Front Panel Controls and Their Use	4
The Rear Panel	5
Some Suggested Settings	6
Troubleshooting	7
System Block Diagram	7
Technical Specifications	back cover

	CAUTION RISK OF ELECTRIC SHOCK DO NOT OPEN	
WARNING: TO REDUCE THE RISK OF FIRE OR ELECTRIC SHOCK, DO NOT EXPOSE THIS APPARATUS TO RAIN OR MOISTURE. TO REDUCE THE RISK OF ELECTRIC SHOCK, DO NOT REMOVE COVER. NO USER-SERVICEABLE PARTS INSIDE. REFER SERVICING TO QUALIFIED SERVICE PERSONNEL.		

	PRECAUCION RIESGO DE CORRIENTAZO NO ABRA	
PRECAUCION: PARA REDUCIR EL RIESGO DE INCENDIOS O DESCARGAS ELECTRICAS, NO PERMITA QUE ESTE APARATO QUEDA EXPUESTO A LA LLUVIA O LA HUMEDAD. PARA DISMINUIR EL RIESGO DE CORRIENTAZO, NO ABRA LA CUBIERTA. NO HAY PIEZAS ADENTRO QUE EL USUARIO PUEDA REPARAR DEJE TODO MANTENIMIENTO A LOS TECNICOS CALIFICADOS.		

	ATTENTION RISQUE D'ELECTROCUTION NE PAS OUVRIR	
ATTENTION: PROTEGEZ CET APPAREIL DE LA PLUIE ET DE L'HUMIDITE AFIN D'EVITER TOUT RISQUE D'INCENDIE OU D'ELECTROCUTION. POUR REDUIRE D'ELECTROCUTION NE PAS ENLEVER LE COUVERCLE. AUCUNE PIECE INTERNE N'EST REPARABLE PAR L'UTILISATEUR. POUR TOUTE REPARATION, S'ADRESSER A UN TECHNICIEN QUALIFIE.		

IMPORTANT SAFETY INSTRUCTIONS

- READ, FOLLOW, HEED, AND KEEP ALL INSTRUCTIONS AND WARNINGS.
- DO NOT OPERATE NEAR ANY HEAT SOURCE AND DO NOT BLOCK ANY VENTILATION OPENINGS ON THIS APPARATUS. FOR PROPER OPERATION, THIS UNIT REQUIRES 3" (75CM) OF WELL VENTILATED SPACE AROUND HEATSINKS AND OTHER AIR FLOW PROVISIONS IN THE CABINET.
- DO NOT USE THIS APPARATUS NEAR SPLASHING, FALLING, SPRAYING, OR STANDING LIQUIDS.
- CLEAN ONLY WITH LINT-FREE DAMP CLOTH AND DO NOT USE CLEANING AGENTS.
- ONLY CONNECT POWER CORD TO A POLARIZED, SAFETY GROUNDED OUTLET WIRED TO CURRENT ELECTRICAL CODES AND COMPATIBLE WITH VOLTAGE, POWER, AND FREQUENCY REQUIREMENTS STATED ON THE REAR PANEL OF THE APPARATUS.
- PROTECT THE POWER CORD FROM DAMAGE DUE TO BEING WALKED ON, PINCHED, OR STRAINED.
- UNPLUG THE APPARATUS DURING LIGHTNING STORMS OR WHEN UNUSED FOR LONG PERIODS OF TIME.
- ONLY USE ATTACHMENTS, ACCESSORIES, STANDS, OR BRACKETS SPECIFIED BY THE MANUFACTURER FOR SAFE OPERATION AND TO AVOID INJURY.
- WARNING: TO REDUCE THE RISK OF ELECTRIC SHOCK OR FIRE, DO NOT EXPOSE THIS UNIT TO RAIN OR MOISTURE.
- SERVICE MUST BE PERFORMED BY QUALIFIED PERSONNEL.
- OUR AMPLIFIERS ARE CAPABLE OF PRODUCING HIGH SOUND PRESSURE LEVELS. CONTINUED EXPOSURE TO HIGH SOUND PRESSURE LEVELS CAN CAUSE PERMANENT HEARING IMPAIRMENT OR LOSS. USER CAUTION IS ADVISED AND EAR PROTECTION IS RECOMMENDED IF UNIT IS OPERATED AT HIGH VOLUME.



EXPLANATION OF GRAPHICAL SYMBOLS:
EXPLICACION DE SIMBOLOS GRAFICOS:
EXPLICATION DES SYMBOLES GRAPHIQUES:

= "DANGEROUS VOLTAGE"
"VOLTAJE PELIGROSO"
"DANGER HAUTE TENSION"

= "IT IS NECESSARY FOR THE USER TO REFER TO THE INSTRUCTION MANUAL"
"ES NECESARIO QUE EL USUARIO SE REFIERA AL MANUAL DE INSTRUCCIONES."
"REFERREZ-VOUS AU MANUAL D'UTILISATION"

An introduction To Your New Ampeg BA500 Bass Amp Combo

Thank you for making one of the best choices you will ever make for your musical career – choosing one of the finest bass amplifiers available, the Ampeg BA500.

Your new BA500 bass amp combo provides many outstanding features which make this a true performer's bass amp: 350 watts of power at four ohms, 500 watts at two ohms, a 45 degree tilt-back cabinet design, total tone control, and rugged construction.

Features

In the world of high performance bass amps, Ampeg amplifiers stand alone. In true Ampeg tradition, the BA500 offers you more power, performance and flexibility than any other bass amplifier in its class. The outstanding features of your new amplifier, features which set it apart from the competition, are listed below.

- **500 WATTS AT 2 OHMS:** With the addition of a four ohm external speaker cabinet, the BA500 will deliver an astounding 500 watts of power into a two ohm load.
- **9-BAND GRAPHIC EQ:** Use as a “second channel” for bass solos, or to shape your sound to your own exacting standards. Can be controlled by means of a footswitch.
- **MUTE SWITCH:** Allows silent tuning while on stage, or noise-free switching between instruments. Can be controlled by a footswitch.
- **BALANCED LINE OUTPUT:** XLR with independent level switch (20dB pad). Patch into house consoles, mixing boards, or external power amplifiers.
- **EFFECTS LOOP:** For increased intensity and quieter operation of external effects.
- **POWER AMP IN and PREAMP OUT:** Allows direct access into the power amp and a signal tap from the preamp section for even greater versatility.
- **TUNER OUT JACK:** Allows the use of an external tuner - even when the Mute function is active.
- **BUILT-IN PROTECTION:** Internal protection circuitry for short circuits, DC voltage, low voltage, and over-temperature conditions.
- **CLASSIC AMPEG SOUND AND PERFORMANCE!**



The Front Panel Controls and Their Use

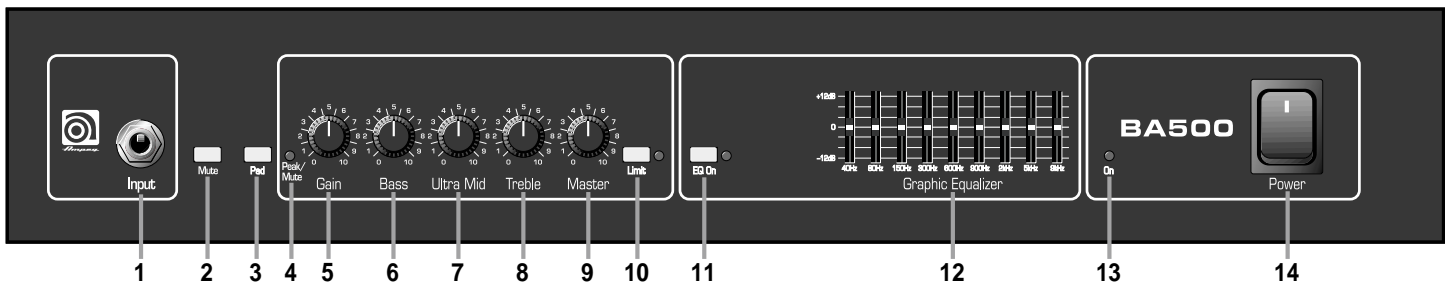

1. INPUT: Connect your instrument here by means of a shielded instrument cable.

2. MUTE: This switch, when depressed, mutes the output of the amplifier to the speakers. This is excellent for tuning your bass with an electronic tuner without having to adjust any levels or turn down your stage volume. When a footswitch is used (see #19, rear panel) this switch is disabled. The Tuner Out and Bal. Out jacks (#21 and #27) are unaffected by the Mute switch.

3. PAD: This switch, when depressed, attenuates the input signal by 15dB. Attenuation allows the Gain control (#5) to be used in a more usable (higher) position. If clipping is indicated with the Gain control way down, attenuation is needed.

4. PEAK/MUTE LED: This LED flashes when the signal level into the preamp (excluding the graphic EQ) approaches clipping. Adjust the Gain control (#5) until a strong signal from your instrument causes this LED to flicker. When the Mute function is engaged this LED remains fully illuminated.

NOTE: If the LED flashes frequently with the gain at a low setting, use the Pad switch (#3) to attenuate the input signal and readjust the Gain (#5).

5. GAIN: Use this control to adjust the input level of the amplifier. For the best signal-to-noise set this control so the Peak/Mute LED (#4) flashes when you strike a string fairly hard.

6. BASS: This is the primary low frequency control. It allows for a range of 8dB of boost or 18dB of cut at 50Hz.

7. ULTRA-MID: The primary midrange control. Rotate the control to the left of center for a “contoured” sound (more distant, less midrange output) or to the right of center for a sound which really cuts through.

8. TREBLE: This is the primary high frequency control. It allows for a range of 12dB boost or 24dB of cut at 5kHz.

9. MASTER: Set the overall output level of the amplifier with this control. The Effects Loop and Balanced Out (#23-27) are not affected by the Master control.

10. LIMIT: The BA500 uses an internal Optocoupler Limiter to assist in keeping the power amplifier’s output “clean” at extreme volume levels. (All amplifiers may begin to clip their output signals as they approach maximum output levels, resulting in potentially damaging distortion.) To engage the Limiter, depress the Limit switch. The adjacent LED illuminates whenever the limiter

circuit is activated. This indicates that the amplifier is nearing full output and the limiter is keeping peak signals from clipping the output.

NOTE: Playing at full power with the Limiter off will give you increased output power, but the sound may be distorted. Use discretion when playing without the Limiter.

11. EQ ON: Depress this switch to activate the Graphic EQ. The adjacent LED illuminates when the EQ is on. When a footswitch is used (see #19, rear panel) this switch is disabled.

12. GRAPHIC EQ: These sliders control the output of the frequencies indicated below each control. The center position of each control is flat (no boost or cut).

13. ON LED: This LED indicator illuminates when the POWER switch (#14) is ON.

14. POWER: This heavy-duty rocker switch applies the power to the amplifier. The amp is ON when the top of the switch is depressed, OFF when the bottom of the switch is depressed.

The Rear Panel

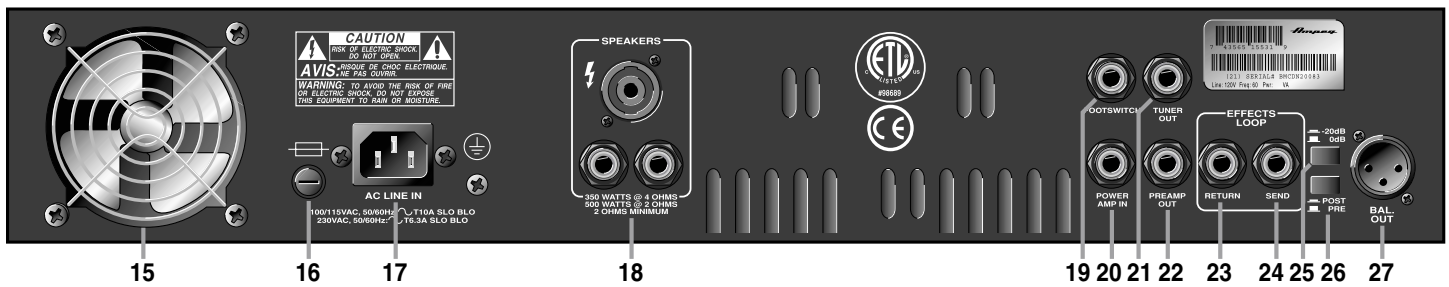

15. FAN: The temperature controlled, variable speed fan pulls cool air through the amplifier's intake vents, forcing heat out through the fan. Never block the air intake holes or the fan opening.

NOTE: It is not uncommon for the fan to remain off when the amplifier is first powered up.

16. FUSE: The fuse protects the unit from damage due to overload conditions or power line surges. If the fuse fails, replace it only with the same size and type.

17. AC LINE IN: Firmly insert the female end of the supplied AC power cord into this socket. The grounded power cord should only be plugged into a grounded power outlet that meets all applicable electrical codes and is compatible with the voltage, power, and frequency requirements stated on the rear panel. **Do not attempt to defeat the safety ground connection.**

18. SPEAKERS: Use these jacks to connect the amplifier to your speaker(s) using cables terminated with the appropriate connectors. Always use high-quality speaker cables for these connections.

NOTE: When connecting multiple speaker cabinets to the amplifier, keep the overall impedance at or above two ohms! The BA500's internal speakers count as one four ohm cabinet. The following chart shows the total impedance load when connecting speaker cabinets in parallel:

Cabinet Impedance	# of Cabs	Total Impedance
4Ω	2	2Ω
8Ω	2	4Ω
8Ω	4	2Ω
16Ω	2	8Ω
16Ω	4	4Ω

19. FOOTSWITCH: Use this jack to connect a two-button footswitch for remote control of the Mute and Graphic EQ. Tip = Mute, ring = EQ, sleeve = ground. When a footswitch is used the corresponding front panel switches (#2 and #11) are disabled.

20. POWER AMP IN: This mono jack allows you to feed the preamp output of another amplifier to the input of the BA500's internal power amp. This bypasses the preamp circuitry of the amplifier.

21. TUNER OUT: Use this jack to send a signal to an electronic tuner. This jack is always "live," even when the Mute switch (#2) is engaged, allowing for "silent tuning" as well as a monitor feed which remains active when the speakers are muted.

22. PREAMP OUT: A post-EQ signal may be taken from this jack and sent to the house mixing board, recording console or external power amplifier.

23. EFFECTS LOOP RETURN: To use an external effects device, connect the OUTPUT of the device to the Return jack by means of a shielded cable. This feeds the processed signal into the Master section of the BA500.

24. EFFECTS LOOP SEND: Connect the output from the Send jack to the INPUT of your effects by means of a shielded cable. This sends a post-EQ signal to your effects.

25. -20dB/0dB: This switch, when depressed, attenuates the output level at the Bal. Out jack (#27), resulting in a signal that is more compatible with the microphone inputs on a mixer. This switch works independently from the front panel Master control.

26. POST/PRE: You can select either Pre or Post EQ for the signal at the Balanced Out jack (#27) with this switch. With the switch in the OUT position, the signal at the jacks will be Pre-EQ. This is a direct output not affected by any EQ or boost settings. When the switch is depressed, the signal is Post-EQ and is controlled and modified by the tone controls, Graphic EQ, and Effects Loop.

27. BAL. OUT: This XLR-type connector supplies a balanced preamp output signal for connecting to a house mixing board, recording console or external amplifiers with balanced inputs. The signal can be set to Pre or Post EQ by the Post/Pre switch (#26). The level can be adjusted for either mic or line type inputs using the -20dB/0dB switch (#25).

28. HF LEVEL CONTROL (cabinet back, not shown): Use this control to adjust the output level of the high frequency driver. With the control fully counter clockwise, there is no output from the high frequency driver. The output from the high frequency driver increases as you rotate this control clockwise.



Some Suggested Settings

The setting of the Gain control depends on your particular instrument. The Master should be set to produce the appropriate output volume level. The Graphic EQ can be used to tailor the amplifier to your speaker cabinets, to compensate for room acoustics and to "fine tune" your sound.

ROCK:

Control panel for ROCK settings. The left side features five knobs: Gain (Peak/Mute), Bass, Ultra Mid, Treble, and Master (Limit). The right side features a Graphic Equalizer with an EQ On button and eight frequency sliders (40Hz, 80Hz, 150Hz, 300Hz, 600Hz, 900Hz, 2kHz, 5kHz, 9kHz) all set to 0dB.

JAZZ:

Control panel for JAZZ settings. The left side features five knobs: Gain (Peak/Mute), Bass, Ultra Mid, Treble, and Master (Limit). The right side features a Graphic Equalizer with an EQ On button and eight frequency sliders (40Hz, 80Hz, 150Hz, 300Hz, 600Hz, 900Hz, 2kHz, 5kHz, 9kHz) all set to 0dB.

COUNTRY:

Control panel for COUNTRY settings. The left side features five knobs: Gain (Peak/Mute), Bass, Ultra Mid, Treble, and Master (Limit). The right side features a Graphic Equalizer with an EQ On button and eight frequency sliders (40Hz, 80Hz, 150Hz, 300Hz, 600Hz, 900Hz, 2kHz, 5kHz, 9kHz) all set to 0dB.

FUNK "POPPING:"

Control panel for FUNK "POPPING:" settings. The left side features five knobs: Gain (Peak/Mute), Bass, Ultra Mid, Treble, and Master (Limit). The right side features a Graphic Equalizer with an EQ On button and eight frequency sliders (40Hz, 80Hz, 150Hz, 300Hz, 600Hz, 900Hz, 2kHz, 5kHz, 9kHz) all set to 0dB.

Troubleshooting

In the unlikely event that your BA500 should stop working properly (or just stop working), take a few minutes to troubleshoot it before you call for service. You can save yourself a lot of time and sometimes money by doing it yourself, and often the cure for the problem is something quite simple.

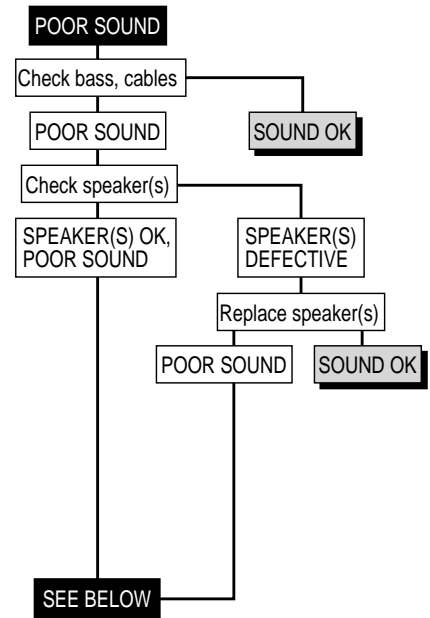
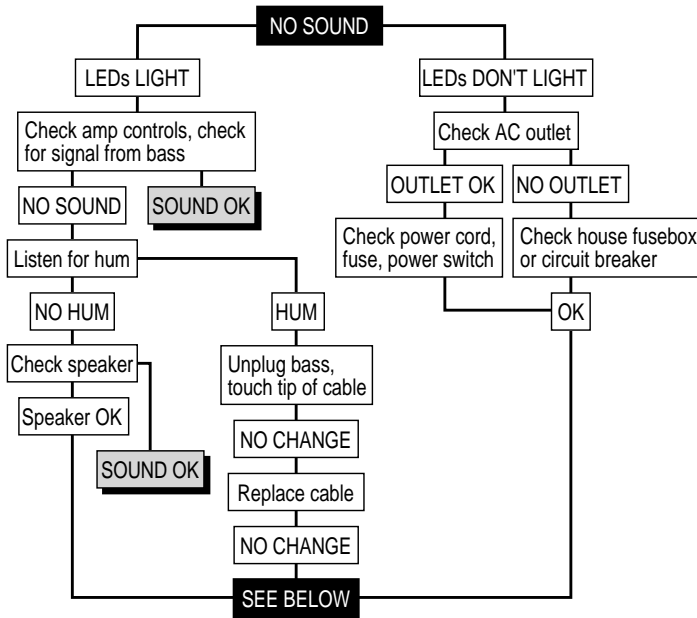

If the problem isn't covered above, or if the steps lead you here, then contact your Ampeg dealer for service information. Also, you should refer your amp to an authorized service center for servicing if it gets dropped, has liquid spilled into it, or sustains damage to its power cord. Regular cleaning and maintenance by your local Service Center will help extend the amplifier's useful life.

System Block Diagram

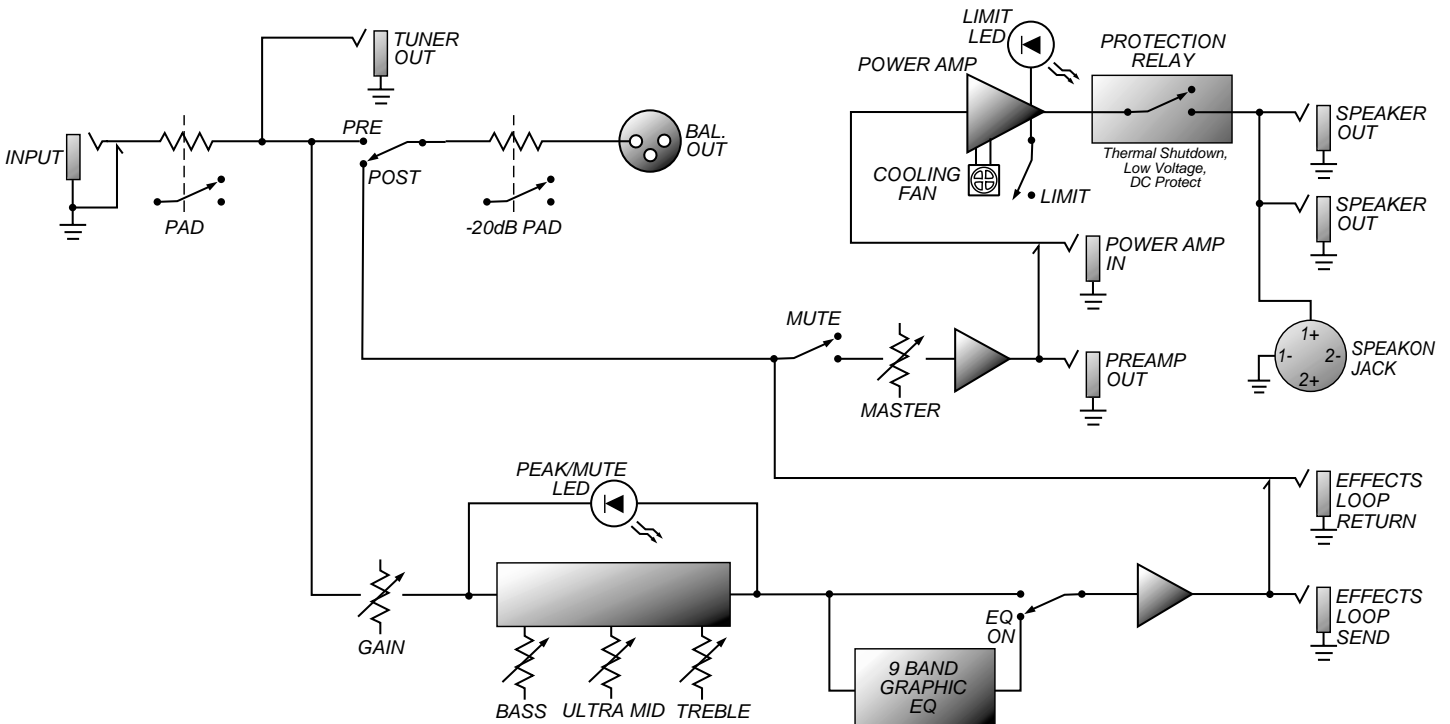



Technical Specifications

OUTPUT POWER RATING	350 Watts RMS, 4 ohm load, 120VAC, 5% THD 540 Watts RMS, 2 ohm load, 120VAC, 5% THD
TONE CONTROL RANGE	Bass: +8dB / -18dB @ 50Hz Ultra Mid: ±8dB @ 500Hz Treble: +12dB / -24dB @ 5kHz
GRAPHIC EQ RANGE	40Hz: ±11dB 80Hz: ±8dB 150Hz: ±8dB 300Hz: ±8dB 600Hz: ±8dB 900Hz: ±8dB 2kHz: ±8dB 5kHz: ±8dB 9kHz: ±12dB
GAIN	60dB typical, tones @ center
SIGNAL TO NOISE RATIO	75dB typical
INTERNAL SPEAKERS	(2) 10" cast frame, 225W, 8 ohm, 2.5" voice coil diameter, 56 oz. magnet (1) 1" compression driver with L-pad control
POWER REQUIREMENTS	120VAC, 60Hz, 400VA 100VAC, 50/60Hz, 400VA 230VAC, 50/60Hz, 400VA
SIZE AND WEIGHT	24"W x 23.5"H x 17.25"D, 95 lbs.

Ampeg reserves the right to change specifications without notice.

