Ampex



Heritage

MODEL B-15

BASS AMPLIFIER

HAND-WIRED AND ASSEMBLED

IN THE USA

Owner's Manual



IMPORTANT SAFETY INSTRUCTIONS

1. Read these instructions.
2. Keep these instructions.
3. Heed all warnings.
4. Follow all instructions.
5. Do not use this apparatus near water.
6. Clean only with a dry cloth.
7. Do not block any ventilation openings. Install in accordance with the manufacturer's instructions.
8. Do not install near any heat sources such as radiators, heat registers, stoves, or other apparatus (including amplifiers) that produce heat.
9. Do not defeat the safety purpose of the polarized or grounding-type plug. A polarized plug has two blades with one wider than the other. A grounding-type plug has two blades and a third grounding prong. The wide blade or the third prong are provided for your safety. If the provided plug does not fit into your outlet, consult an electrician for replacement of the obsolete outlet.
10. Protect the power cord from being walked on or pinched particularly at plugs, convenience receptacles, and the point where they exit from the apparatus.
11. Only use attachments/accessories specified by the manufacturer.
12. Use only with a cart, stand, tripod, bracket, or table specified by the manufacturer, or sold with the apparatus. When a cart is used, use caution when moving the cart/apparatus combination to avoid injury from tip-over.
13. Unplug this apparatus during lightning storms or when unused for long periods of time.
14. Refer all servicing to qualified service personnel. Servicing is required when the apparatus has been damaged in any way, such as power-supply cord or plug is damaged, liquid has



- been spilled or objects have fallen into the apparatus, the apparatus has been exposed to rain or moisture, does not operate normally, or has been dropped.
15. Do not overload wall outlets and extension cords as this can result in a risk of fire or electric shock.
 16. This apparatus shall not be exposed to dripping or splashing, and no object filled with liquids, such as vases or beer glasses, shall be placed on the apparatus.
 17. This apparatus has been designed with Class-I construction and must be connected to a mains socket outlet with a protective earthing connection (the third grounding prong).
 18. The MAINS plug or an appliance coupler is used as the disconnect device, so the disconnect device shall remain readily operable.
 19. For the terminals marked with symbol of “⚡” may be of sufficient magnitude to constitute a risk of electric shock. The external wiring connected to the terminals requires installation by an instructed person or the used of ready-made leads or cords.

	CAUTION AVIS RISK OF ELECTRIC SHOCK. DO NOT OPEN RISQUE DE CHOC ELECTRIQUE. NE PAS OUVRIR	
<p>CAUTION: TO REDUCE THE RISK OF ELECTRIC SHOCK DO NOT REMOVE COVER (OR BACK) NO USER-SERVICEABLE PARTS INSIDE. REFER SERVICING TO QUALIFIED PERSONNEL</p> <p>ATTENTION: POUR EVITER LES RISQUES DE CHOC ELECTRIQUE, NE PAS ENLEVER LE COUVERCLE. AUCUN ENTRETIEN DE PIECES INTERIEURES PAR L'USAGER. CONFIER L'ENTRETIEN AU PERSONNEL QUALIFIE.</p> <p>AVIS: POUR EVITER LES RISQUES D'INCENDIE OU D'ELECTROCUTION, N'EXPOSEZ PAS CET ARTICLE A LA PLUIE OU A L'HUMIDITE</p>		

	<p>The lightning flash with arrowhead symbol within an equilateral triangle is intended to alert the user to the presence of uninsulated "dangerous voltage" within the product's enclosure, that may be of sufficient magnitude to constitute a risk of electric shock to persons.</p> <p>Le symbole éclair avec point de flèche à l'intérieur d'un triangle équilatéral est utilisé pour alerter l'utilisateur de la présence à l'intérieur du coffret de "voltage dangereux" non isolé d'ampleur suffisante pour constituer un risque d'électrocution.</p>
	<p>The exclamation point within an equilateral triangle is intended to alert the user of the presence of important operating and maintenance (servicing) instructions in the literature accompanying the appliance.</p> <p>Le point d'exclamation à l'intérieur d'un triangle équilatéral est employé pour alerter les utilisateurs de la présence d'instructions importantes pour le fonctionnement et l'entretien (service) dans le livret d'instruction accompagnant l'appareil.</p>

WARNING — To reduce the risk of fire or electric shock, do not expose this apparatus to rain or moisture.



Correct disposal of this product: This symbol indicates that this product should not be disposed of with your household waste, according to the WEEE directive (2002/96/EC) and your national law. This product should be handed over to an authorized collection site for recycling waste electrical and electronic equipment (EEE). Improper handling of this type of waste could have a possible negative impact on the environment and human health due to potentially hazardous substances that are generally associated with EEE. At the same time, your cooperation in the correct disposal of this product will contribute to the effective usage of natural resources. For more information about where you can drop off your waste equipment for recycling, please contact your local city office, waste authority, or your household waste disposal service.



NOTE: This equipment has been tested and found to comply with the limits for a Class B digital device, pursuant to part 15 of the FCC Rules. These limits are designed to provide reasonable protection against harmful interference in a residential installation. This equipment generates, uses, and can radiate radio frequency energy and, if not installed and used in accordance with the instructions, may cause harmful interference to radio communications. However, there is no guarantee that interference will not occur in a particular installation. If this equipment does cause harmful interference to radio or television reception, which can be determined by turning the equipment off and on, the user is encouraged to try to correct the interference by one or more of the following measures:

- Reorient or relocate the receiving antenna.
- Increase the separation between the equipment and the receiver.
- Connect the equipment into an outlet on a circuit different from that to which the receiver is connected.
- Consult the dealer or an experienced radio/TV technician for help.

CAUTION: Changes or modifications to this device not expressly approved by LOUD Technologies Inc. could void the user's authority to operate the equipment under FCC rules.

This apparatus does not exceed the Class A/Class B (whichever is applicable) limits for radio noise emissions from digital apparatus as set out in the radio interference regulations of the Canadian Department of Communications.

ATTENTION — Le présent appareil numérique n'émet pas de bruits radioélectriques dépassant les limites applicables aux appareils numériques de class A/de class B (selon le cas) prescrites dans le règlement sur le brouillage radioélectrique édicté par le ministère des communications du Canada.

Exposure to extremely high noise levels may cause permanent hearing loss. Individuals vary considerably in susceptibility to noise-induced hearing loss, but nearly everyone will lose some hearing if exposed to sufficiently intense noise for a period of time. The U.S. Government's Occupational Safety and Health Administration (OSHA) has specified the permissible noise level exposures shown in the following chart.

According to OSHA, any exposure in excess of these permissible limits could result in some hearing loss. To ensure against potentially dangerous exposure to high sound pressure levels, it is recommended that all persons exposed to equipment capable of producing high sound pressure levels use hearing protectors while the equipment is in operation. Ear plugs or protectors in the ear canals or over the ears must be worn when operating the equipment in order to prevent permanent hearing loss if exposure is in excess of the limits set forth here:

Duration, per day in hours	Sound Level dBA, Slow Response	Typical Example
8	90	Duo in small club
6	92	
4	95	Subway Train
3	97	
2	100	Very loud classical music
1.5	102	
1	105	The bass screaming at his minions about manual deadlines
0.5	110	
0.25 or less	115	Loudest parts at a rock concert

CONSIGNES DE SECURITE IMPORTANTES

- LIRE, SUIVRE TOUTES LES INSTRUCTIONS ET LES PRECAUTIONS D'UTILISATION
- NE PAS UTILISER PROCHE D'UNE SOURCE DE CHALEUR ET NE PAS BLOQUER LE SYSTEME DE VENTILATION SUR CET APPAREIL. POUR UNE UTILISATION CONFORME, CET APPAREIL NECESSITE ENVIRON 7CM D'ESPACE BIEN VENTILE AUTOUR DE SON SYSTEME DE REFROIDISSEMENT, AINSI QU'UN COURANT D'AIR FRAIS CONSTANT
- NE PAS UTILISER CET APPAREIL PROCHE D'UNE SOURCE LIQUIDE
- NETTOYER SEULEMENT A L'AIDE D'UN CHIFFON DOUX ET SEC ET NE PAS UTILISER DE PRODUITS MENAGERS
- CONNECTER UNIQUEMENT LE CABLE D'ALIMENTATION FOURNI SUR UNE PRISE AVEC MISE A LA TERRE, ET COMPATIBLE AVEC LA TENSION, L'INTENSITE ET LA FREQUENCE REQUISES INDIQUEES SUR LA FACE ARRIERE DE L'APPAREIL
- S'ASSURER DE NE PAS MARCHER, PLIER OU TIRER SUR LE CABLE D'ALIMENTATION
- DEBRANCHER L'APPAREIL LORS D'UNE TEMPETE OU LORS D'UNE TRES LONGUE PERIODE DE NON UTILISATION
- UTILISER UNIQUEMENT DES ACCESSOIRES SPECIFIES PAR LE FABRICANT POUR UNE UTILISATION EN TOUTE SECURITE ET POUR EVITER DES BLESSURES
- **ATTENTION:** AFIN DE PREVENIR TOUT RISQUE DE CHOCS ELECTRIQUES OU DE DEBUT D'INCENDIE, NE PAS EXPOSER CET APPAREIL A LA PLUIE ET A L'HUMIDITE
- TOUT ENTRETIEN DOIT ETRE FAIT PAR UN TECHNICIEN QUALIFIE
- NOS AMPLIFICATEURS PEUVENT PRODUIRE DE TRES HAUTES PRESSIONS ACOUSTIQUES QUI PEUVENT CAUSER DES DOMMAGES AUDITIFS PERMANENTS OU DEFINITIFS. L'UTILISER AVEC UNE GRANDE PRECAUTION EST CONSEILLE ET DES PROTECTIONS AUDITIVES SONT RECOMMANDEES POUR UNE UTILISATION A FORT VOLUME.
- **ATTENTION:** CET APPAREIL REQUIERT UNE PRISE MURALE AVEC MISE A LA TERRE, AUX NORMES ACTUELLES ET COMPATIBLE AVEC LES SPECIFICATIONS ELECTRIQUES SE TROUVANT EN FACE ARRIERE DE L'APPAREIL. LA PRISE ELECTRIQUE DOIT RESTER ACCESSIBLE POUR DEBRANCHER L'APPAREIL EN CAS DE DEFAUT PENDANT L'UTILISATION
- CET APPAREIL DOIT ETRE DEBRANCHE SI IL N'EST PAS UTILISE

Élimination correcte du produit : Ce symbole indique que ce produit ne doit pas être éliminé avec les ordures ménagères, comme le prévoit la directive WEEE (2002/96/EC) et votre loi nationale.

Ce produit doit être remis à un site de recyclage des déchets électriques et des équipements électroniques (EEE).

Un mauvais recyclage de ce type de déchet peut avoir de possibles impacts négatifs sur l'environnement et la santé humaine dus aux émanations de substances.

Dans un même temps, votre coopération à un recyclage correct de ce produit contribuera à la bonne utilisation des ressources naturelles.

Pour connaître l'endroit où il est possible de recycler ces équipements, merci de contacter votre mairie, les services de recyclages ou le service des déchets ménagers.



Features:

- Hand-wired and assembled in the U.S.A.
- 2012 Limited edition production
 - Only 100 units available
 - Numbered and matched heads/cabs
- Classic Ampeg flip-top design
 - Chrome-plated chassis
 - Rugged cabinets made with Baltic birch and poplar
 - Dovetail joint box construction
 - Legendary double-baffle cabinet design delivers classic tone
- Two distinct hand-wired preamp circuits
 - Channel 1 – 1964 (B-15NC)
 - Channel 2 – 1966 (B-15NF)
- Selectable bias modes for ultimate tone control
 - 1964 – cathode bias (25W @ 4 or 8 Ω)
 - 1966 – fixed bias (30W @ 4 or 8 Ω)
- High-grade tubes
 - Preamp – 3 x 6SL7
 - Rectifier – 1 x 5AR4
 - Power amp – 2 x 6L6GC
- Legendary Baxandall bass/treble tone stack on both channels
- Dual inputs per channel (0 dB and –15 dB)
- Custom-designed 15" U.S.–made Eminence® driver
 - 4" voice coil
 - 109 oz ceramic magnet
 - Aluminum dust cover
- External amplifier out
- Removable dolly with casters
- Dimensions (H x W x D): 27" x 21" x 14" w/dolly
- Weight (with dolly): 99 lb / 45 kg

Table of Contents:

Important Safety Instructions	2
Introduction / Features	3
Heritage B-15 Front Panel	5
Heritage B-15 Rear Panel	6
Important Information About Tubes	7
Heritage B-15 Block Diagram	10
Heritage B-15 Specifications	11
Heritage B-15 Service Information	12

Introduction

Hand-wired and assembled in the U.S.A., the Ampeg Heritage B-15 delivers legendary tone in a design that truly lives up to the iconic standard set by inventor Jess Oliver over 50 years ago. The Heritage B-15 features the circuit paths of both a 1964 and 1966 B-15, including classic Baxandall EQ controls and premium 6SL7 octal preamp tubes along with a bias switch, recreating each year's distinctive bias methodology.

The extremely high-quality flip-top cabinet features the legendary double-baffle design and houses a highly-researched, custom-designed 15" Eminence driver. The Heritage B-15 is no mere tribute; it meets and exceeds the performance, look and tone of the legendary original, down to each and every component.

In order to get the most out of the Heritage B-15, please read this manual before you begin playing.

Best of luck in all of your musical endeavors!

Sincerely,

The dedicated team at Ampeg



Heritage B-15 Front Panel

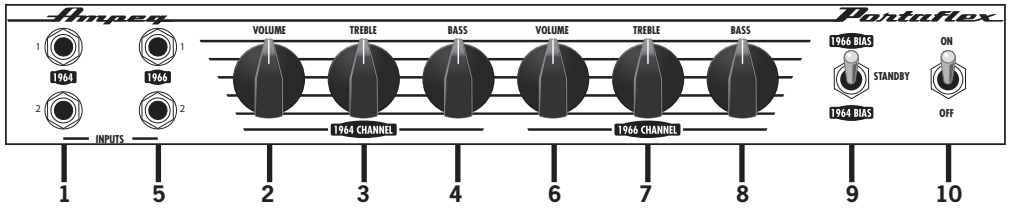

1964:

1. **INPUT:** The signal output from an instrument (active or passive) may be connected to one of the two 1/4" inputs by means of a shielded instrument cable. The top #1 input jack is 0 dB while the bottom #2 input jack is -15 dB. This channel replicates the same circuitry as the classic 1964 B-15NC.
2. **VOLUME:** This controls the overall output level to the speaker outputs. Use it wisely, and turn it down when making connections.
3. **TREBLE:** Use this to adjust the high frequency level of the amplifier. This provides up to 18 dB of boost or cut at 5 kHz. The high frequency output is flattest at the center position.
4. **BASS:** Use this to adjust the low frequency level of the amplifier. This provides up to 10 dB of boost or cut at 40 Hz. The low frequency output is flattest at the center position.

1966:

5. **INPUT:** The signal output from an instrument (active or passive) may be connected to one of the two 1/4" inputs by means of a shielded instrument cable. The top #1 input jack is 0 dB while the bottom #2 input jack is -15 dB. This channel replicates the same circuitry as the classic 1966 B-15NF.

6. **VOLUME:** This controls the overall output level to the speaker outputs. Use it wisely, and turn it down when making connections.
7. **TREBLE:** Use this to adjust the high frequency level of the amplifier. This provides up to 18 dB of boost, or -30 dB of cut at 5 kHz. The high frequency output is flattest at the center position.
8. **BASS:** Use this to adjust the low frequency level of the amplifier. This provides up to 11 dB of boost or cut at 40 Hz. The low frequency output is flattest at the center position.
9. **1966/STANDBY/1964 SWITCH:** Use this switch to activate the amplifier after the On/Off switch [10] is turned on. **Always make sure this switch is in STANDBY mode when powering the Heritage B-15 ON or OFF [10]. Allow at least 30 seconds before selecting between 1966 or 1964.** During short breaks this switch should be set to the Standby position to help prolong the life of the amplifier's tubes.

From Standby, users may now select between 1964 cathode bias or 1966 fixed bias, 1964 or 1966 preamp or have the ability to mix and match.

10. **ON/OFF SWITCH:** Use this switch to turn the overall system power on or off. **Always turn this switch ON first and OFF last! Turn the 1966/Standby/1964 switch [9] to 1966 or 1964 at least 30 seconds after turning on the On/Off switch.**



Heritage B-15 Rear Panel

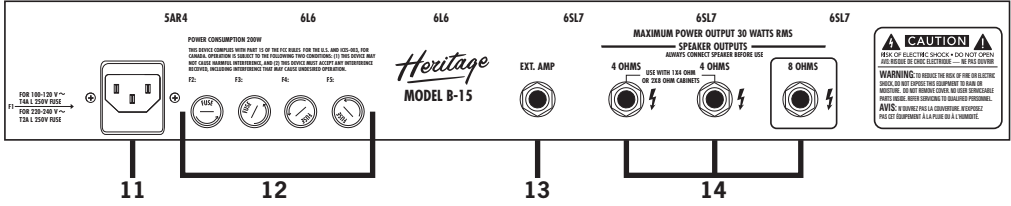

11. IEC POWER INPUT CONNECTOR: This is where you connect the supplied AC power cord.

The MAINS fuse is located inside the IEC socket fuse drawer and should be left alone unless a fuse has blown.

To remove and replace the fuse:

- *Disconnect the power cord from the IEC socket.

- *Remove the fuse drawer.

- *Remove the fuse and replace it with an equivalent-type fuse:

For: 100 – 120 V ~T 4 AL 250 V

For: 220 – 240 V ~T 2 AL 250 V

12. SECONDARY FUSES: Fuses located inside these fuse holder caps should be left alone unless a fuse has blown.

To remove and replace the fuse:

- *Disconnect the power cord from the IEC socket [11].

- *Remove the fuse by turning the fuse holder cap counter-clockwise.

- *Remove the fuse and replace it with an equivalent-type fuse as listed on the rear panel of the chassis:

F2 (Rectifier Fuse): listed on chassis

F3 (High Tension Fuse): listed on chassis

F4 (High Tension Fuse): listed on chassis

F5 (Filament Fuse): listed on chassis

13. EXT. AMP: This feature was originally designed as a means to daisy-chain two or more B-15 amps together for additional power. This new-and-improved Heritage B-15 could also be used as a line out to feed an unbalanced Hi-Z input such as a direct box or a mixer.

Alternately, it may be utilized as an input. Any signal applied here will not be affected by the volume controls [2, 6].

14. SPEAKER OUTPUTS: These 1/4" TS output jacks supply speaker-level power to the speaker cabinet. The rated power output is 30 watts rms into a 4 Ω or 8 Ω load.

The Heritage B-15 cabinet is rated at 8 Ω. When using a single Heritage B-15 cabinet with the Heritage B-15 head, connect the cabinet to the matching 8 Ω speaker output jack using a high quality speaker cable.

When using the Heritage B-15 cabinet with an additional 8 Ω ext. speaker, connect the two (8 Ω) cabinets to the two provided 4 Ω jacks using two high quality speaker cables. (Two 8 Ω cabinets in parallel equal a 4 Ω load).

When using the Heritage B-15 cabinet with one 4 Ω cabinet, such as a Heritage SVT-410HLF or SVT-810E, connect the single 4 Ω cabinet to either of the 4 Ω speaker output jacks using a high quality speaker cable.

Use speaker cables with 1/4" TS ends only to make the connections. Do not use instrument cables as they may overheat.



Important information about tubes

A brief history of the tube:

In 1883, Thomas Edison discovered that electrons would flow from a suspended filament when enclosed in an evacuated lamp. Years later, in 1905, John Ambrose Fleming expanded on Edison's discovery and created the "Fleming Valve". Then, in 1907, Dr. Lee de Forest added a third component – the grid – to "Fleming's Valve" and the vacuum tube was a fact of life. The door to electronic amplification was now open.

During World War II, data gleaned from their intensive research on the detectors used in radar systems led Bell Telephone Laboratories to the invention of the transistor. This reliable little device gained quick support as the new component for amplification. The death of the vacuum tube seemed imminent as designers, scientists, and engineers reveled in the idea of replacing large, fragile glass tubes with these small, solid-state devices.

However, there were (and still are) many serious listeners who realized that the sound produced by a "transistor" amplifier is significantly different from that produced by a tube amplifier with identical design specifications. They considered the sound produced by these new solid-state devices to be hard, brittle, and lifeless. It was determined that solid-state devices produced a less musical set of harmonics than tubes. When pushed past their limits, they tend to mute the tone and emphasize the distortion.

Tubes, on the other hand, produce a more musical set of harmonics, the intensity of which may be controlled by the player. This characteristic adds warmth and definition to the sound which has become the hallmark of tube amplifiers. When tubes are driven into clipping, the harmonic overtones can be both sweet and pleasing or intense and penetrating, depending on the musician's taste and playing technique.

Over the years, application engineers have designed a number of outstanding solid-state amplifiers that sound very, very good. Some use special circuitry which enables them to simulate distortion characteristics of a tube amplifier. However, the tube amplifier, still held in the highest esteem by many musicians, offers a classic "vintage" sound in a contemporary market.

Tube types and usage:

The Ampeg Heritage B-15 contains three types of tubes: preamplifier tubes, power tubes and a rectifier tube.

Preamplifier tubes amplify the signal from the instrument and shape the sound. They are inherently microphonic (mechanically pick up and transmit external noises). Since these tubes are used in the critical first stages of a tube amplifier's circuitry, it is very important that any replacements are high-quality, low noise/low microphonic tubes for this application. Although tubes of this quality may be difficult to find and typically cost more than "off-the-shelf" tubes, the improvement in performance is worth the investment.

The preamplifier tubes in the Ampeg Heritage B-15 are three 6SL7. These tubes use larger, octal, sockets and are physically larger than most typical preamp tubes (12AX7 / 12AT7 / 12AU7 / ECC81 / ECC82 / ECC83 / 7025). The Ampeg Heritage team chose 6SL7 tubes for period authenticity, as these tubes came standard with the 1964 Ampeg B-15NC and 1966 Ampeg B-15NF. The 6SL7 preamplifier tube closest to the power tubes is used to drive the power tubes. It is possible to change the sound of the amplifier by changing the type of preamp and/or driver tubes. When making any modification to your equipment, it is highly recommended that you consult with a qualified service center.



Tube types and usage continued...

Power tubes are the largest tubes used in an amplifier, generate the most heat and wear out the fastest. These tubes convert the low-level, conditioned signal from the preamplifier into a level that is sufficient to drive the speakers. There are several types of power tubes available, each of which offers a different performance/sound characteristic. The Ampeg Heritage B-15 uses two 6L6GC. As with the preamp tube selection, the 6L6GC was selected for period authenticity. When replacing power tubes, please replace them with a tested, matched pair and have the amp rebiased by a qualified service center. It is possible to change the sound of the amplifier by changing the type of power tubes. When making any modification to your equipment, it is highly recommended that you consult with a qualified service center.

Rectifier tubes convert the high voltage AC from the power transformer to a high voltage DC supply that powers all the other tubes. Rectifier tubes give the amplifier much of the compression “feel” as maximum output power is approached. This, in turn, is one of the keys to an amplifier’s responsiveness to the musician. The Ampeg Heritage B-15 uses a single 5AR4 (GZ34S) for rectification to mimic the 1964 – 1966 era circuit. Like all of the other tubes, these rectifier tubes were also chosen for period authenticity. When making any modification to your equipment, it is highly recommended that you consult with a qualified service center.

The nature of tubes – why (and when) to replace them:

Tubes are made up of a number of fragile mechanical components that are vacuum-sealed in a glass envelope or bubble. The tube’s longevity is based on a number of factors which include how hard and often the amplifier is played, vibration from the speakers, road travel, repeated setup and tear down, etc.

Any time you notice a change in the amplifier’s performance, check the tubes first.

If it’s been awhile since the tubes were replaced and the sound from the amplifier lacks punch, fades in and out, loses highs or lows or produces unusual sounds, the power tubes probably need to be replaced. If the amplifier squeals, makes noise, loses gain, starts to hum, lacks “sensitivity”, or feels as if it is working against you, the preamplifier tubes may need to be replaced.

The power tubes are subjected to considerably more stress than the preamplifier tubes. Consequently, they almost always fail/degrade first. If deteriorating power tubes aren’t replaced, they will ultimately fail. Depending on the failure mode, they may even cause severe damage to the audio output transformer and/or other components in the amplifier. Replacing the tubes before they fail completely has the potential to save time, money and other unwanted troubles. Since power tubes work together in an amplifier, it is crucial that they (if there is more than one) be replaced by a matched set. If you are on the road a lot, we recommend that you carry a spare matched set of replacement power tubes and their associated driver tubes.

After turning off the power and disconnecting the amplifier from the power source, carefully check the tubes (in bright light) for cracks, white spots inside the glass or any apparent damage. Then, with the power on, view the tubes in a darkened room. Look for the preamplifier tubes that do not glow at all or power tubes that glow excessively red.



The nature of tubes continued...

Whenever replacing power tube(s):

- Always have the amplifier's bias voltage checked by a qualified service center. Improper bias voltage will cause degradation in performance and possibly damage tubes and/or the amplifier. (See the section below titled "The importance of proper biasing" for more information on this subject).
- We highly recommend replacing the driver tube(s), as well. The driver tube determines the shape and amplitude of the signal applied to the power tube(s) and has to work almost as hard as the power tube(s).

You may check the preamplifier tubes for microphonics by turning the amplifier on, turning up the gain and tapping lightly on each tube with the end of a pencil or a chopstick. You will be able to hear the tapping through the speakers, which is normal. It is not normal for a tube to ring like a bell after it is tapped. If it does ring, then it is microphonic and should be replaced. Remember to use only high quality, low microphonic tubes in the preamplifier section.

Even though power tubes are rarely microphonic, they should be checked, anyway. The power tubes may be checked for microphonics just like the preamp tubes.

In the case of very high gain amps, you may be able to reduce the amount of noise generated by simply swapping the preamp tubes around.

The importance of proper biasing:

For the best performance and longest tube life, proper biasing is imperative. Bias (in fixed bias circuits such as the 1966 bias setting) is the negative voltage which is applied to the power tube's control grid to set the level of idle current. We cannot over emphasize the difference in warmth of tone and dynamic response that come with proper biasing. If the bias is set too high (overbiased), the sound from the amp will be distorted at all levels. If the bias is set too low (underbiased), the power tubes will run hot (the plates inside the tubes may glow red due to excessive heat) and the sound from the amplifier will lack power and punch. The excessive heat greatly reduces tube life – from a few days to as little as a few hours in extreme cases. Setting the bias on the amp is like setting the idle on a car. If it's too high or hot, it's running away with you and if it's too low or cold it will choke when you step on it.

The bias is adjusted at the Woodinville, WA, U.S.A. factory by the dedicated Ampeg team. It is important to point out that tubes of the same type and specification typically exhibit different performance characteristics. Consequently, whenever power tubes are replaced, the bias voltage must be checked and re-adjusted to accommodate the operating parameters of the replacement tubes. The bias adjustment should be performed only by qualified service personnel with the proper, calibrated test equipment.

The bottom line:

Only 100 2012 Ampeg Heritage B-15s were hand-wired and assembled in the USA, with the intention of replicating the classic sounds of the 1964 and 1966 models. In order to achieve this, the combo comes standard with 3 6SL7 preamp tubes, 1 5AR4 (GZ34S) rectifier tube and 2 6L6GC power amp tubes. As mentioned earlier, replacing these tubes with different rated ones is possible, but the consequence is a completely different sound. Proceed with caution!



Heritage B-15 Block Diagram

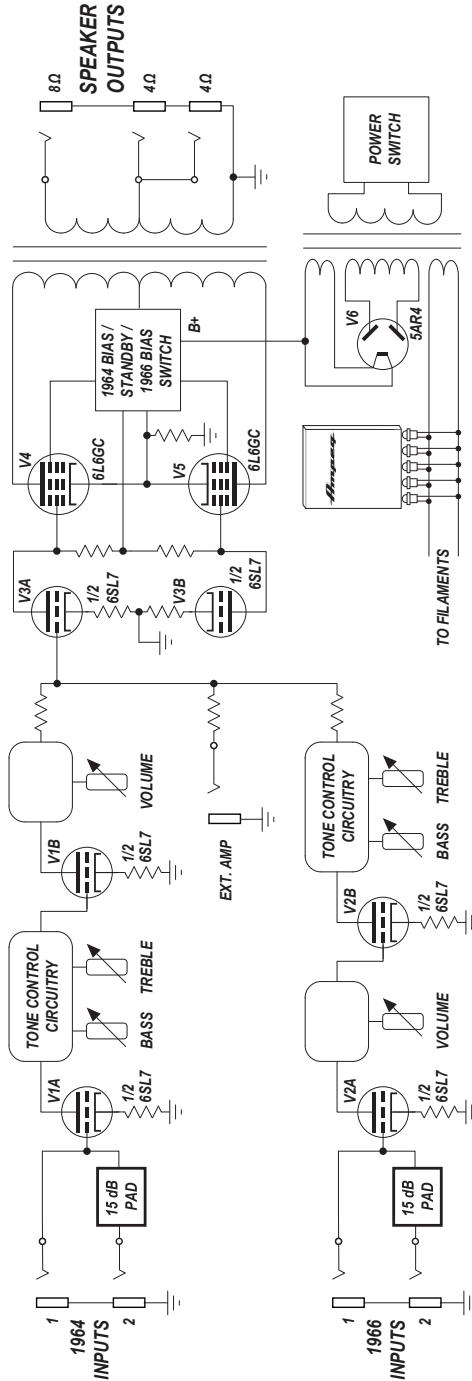



HERITAGE B-15 TECHNICAL SPECIFICATIONS

Preamp Tube 3 x 6SL7

Power Amp Tube 2 x 6L6GC

Rectifier Tube 1 x 5AR4

Two channels

1964 channel is based upon the 1964 B-15NC Preamp Circuit

Two inputs Input 1 is 0 dB, Input 2 is -15 dB
EQ Baxandall Bass +/-10 dB @ 40 Hz
Baxandall Treble +/-18 dB @ 5 kHz

1966 channel is based upon the 1966 B-15NF Preamp Circuit

Two inputs Input 1 is 0 dB, Input 2 is -15 dB
EQ Baxandall Bass +/-11 dB @ 40 Hz
Baxandall Treble +18 / -30 dB @ 5 kHz

Power Tube Bias

1964 Cathode per 1964 era B-15NC

1966 Fixed per 1966 era B-15NF

Output Power Rating (8 or 4 Ω)

1964 Bias 25 watts rms @ 5% THD

1966 Bias 30 watts rms @ 5% THD

Ext Amp I/O Bus

1.25 Vrms (+4 dBu) @ amplifier output clip,
unbalanced bus connection, post volume controls

Speaker Outputs

1 x 8 Ω (Heritage B-15 cabinet)
2 x 4 Ω (One 4 Ω cabinet or two 8 Ω
cabinets; i.e. Heritage B-15 cabinet plus 8 Ω
extension cabinet)

Speaker Specs

Custom-designed 15" Eminence driver
Die-cast aluminum frame
109 oz ceramic magnet
4" Voice Coil
Aluminum dust cover
400W power rating
Made in the U.S.A.



HERITAGE B-15 TECHNICAL SPECIFICATIONS CONTINUED...

Power Requirements	Japan:	100 VAC, 50–60 Hz, 200 watts
	North America:	120 VAC, 50–60 Hz, 200 watts
	UK:	240 VAC, 50–60 Hz, 200 watts
	EU:	220–240 VAC, 50–60 Hz, 200 watts
	Australia:	240 VAC, 50–60 Hz, 200 watts
Cabinet Construction	Highest quality Baltic Birch, solid Poplar and featuring dovetail joint box construction	
Size (H x W x D) with dolly	27 in/686 mm x 21 in/533 mm x 14 in/356 mm	
Weight with dolly	99 lb/45 kg (approximately)	

Flip-Top Instructions:

So you've made it this far and you are now ready to flip your lid...or at least the amp. We will instruct you on how to do the latter, as we are not in the business of lid-flipping!

It is accomplished in five simple steps:

Step 1: loosen the latches on each side of the cabinet. There are two latches on each side, four total.

Step 2: using the handle, lift the top of the cabinet (amplifier is attached underneath) and rotate it 180°.

Step 3: set the cabinet top handle-side down on the top of the cabinet. The amplifier should now be on the top.

Step 4: line up and lock all four latches.

Step 5: connect the amp to the cabinet.

Step 6: connect the power cable to a power source.

Step 7: connect the instrument to the amp.

Step 8: power up the amp.

Step 9: the rest is up to you and the world is your oyster!

Service Information

If you are having a problem with the Heritage B-15, please visit our website (www.ameg.com) and click on Support for service information or call Technical Support at 1-800-898-3211 Monday – Friday during normal business hours, Pacific Time, to receive assistance. If you are outside of the U.S., contact your local distributor for technical support and service.

The Heritage B-15 is covered with sheet metal (amplifier) and a durable fabric-backed vinyl material (cabinet), so be sure to clean with a dry lint-free cloth. Never spray cleaning agents on the Heritage B-15. Avoid abrasive cleansers which would damage the finish.

Ampeg continually develops new products and improves upon existing ones. For this reason, the specifications and information in this manual are subject to change without notice.

"Ampeg" is a registered trademark of LOUD Technologies Inc. All other brand names mentioned are trademarks or registered trademarks of their respective holders and are hereby acknowledged.

www.ameg.com

©2012 LOUD Technologies Inc.

16220 Wood-Red Road NE • Woodinville, WA 98072

Part No. SW0925 Rev. A 08/12