

# SVT

VACUUM TUBE  
DIRECT INJECTION



*User's Guide*











# Ampeg SVTDI Vacuum Tube Direct Injection

## Introduction to the Ampeg SVTDI:

The harmonically rich sound and legendary performance of AMPEG products are redefined in the SVTDI. This Vacuum Tube Direct Injection device delivers unsurpassed quality, reliability and tonal flexibility in a compact, rock-solid package with exceptionally high cosmetic appeal. The SVTDI is easy to operate and is well suited for live performances or for use in the recording studio. Acoustic and electric instruments will benefit from use of the SVTDI.

The SVTDI Vacuum Tube Direct Injection can take an unbalanced line level signal (bass, guitar, keyboard, etc.) and convert it into a balanced signal which can be sent through a long snake to that mixing board so far from the stage - *without degradation of the signal!* The SVTDI offers direct or tube-buffered 1/4" and XLR output connections, and has a switchable 6dB input attenuator to handle "hot" signals.

 <p><b>CAUTION</b> RISK OF ELECTRIC SHOCK DO NOT OPEN</p>  <p>WARNING: TO REDUCE THE RISK OF FIRE OR ELECTRIC SHOCK, DO NOT EXPOSE THIS APPARATUS TO RAIN OR MOISTURE. TO REDUCE THE RISK OF ELECTRIC SHOCK, DO NOT REMOVE COVER. NO USER-SERVICEABLE PARTS INSIDE. REFER SERVICING TO QUALIFIED SERVICE PERSONNEL.</p>	 <p><b>PRECAUCION</b> RIESGO DE CORRIENTAZO NO ABRA</p>  <p>PRECAUCION: PARA REDUCIR EL RIESGO DE INCENDIOS O DESCARGAS ELECTRICAS, NO PERMITA QUE ESTE APARATO QUEDE EXPUERTO A LA LLUVIA O LA HUMEDAD. PARA DISMINUIR EL RIESGO DE CORRIENTAZO, NO ABRA LA CUBIERTA. NO HAY PIEZAS ADENTRO QUE EL USUARIO PUEDE REPARAR. DEJE TODO MANTENIMIENTO A LOS TECNICOS CALIFICADOS.</p>	 <p><b>ATTENTION</b> RISQUE D'ELECTROCUTION NE PAS OUVRIR</p>  <p>ATTENTION: PROTEGEZ CET APPAREIL DE LA PLUIE ET DE L'HUMIDITE AFIN D'EVITER TOUT RISQUE D'INCENDIE OU D'ELECTROCUTION. POUR REDUIRE D'ELECTROCUTION NE PAS ENLEVER LE COUVERCLE. AUCUNE PIECE INTERNE N'EST REPRABLE PAR L'UTILISATEUR. POUR TOUTE REPARATION, S'ADRESSER A UN TECHNICIEN QUALIFIE.</p>
<p><b>IMPORTANT SAFETY INSTRUCTIONS</b></p>		
<ul style="list-style-type: none"> <li>• READ, FOLLOW, HEED, AND KEEP ALL INSTRUCTIONS AND WARNINGS.</li> <li>• DO NOT OPERATE NEAR ANY HEAT SOURCE AND DO NOT BLOCK ANY VENTILATION OPENINGS ON THIS APPARATUS. FOR PROPER OPERATION, THIS UNIT REQUIRES 3" (75mm) OF WELL VENTILATED SPACE AROUND HEATSINKS AND OTHER AIR FLOW PROVISIONS IN THE CABINET.</li> <li>• DO NOT USE THIS APPARATUS NEAR SPLASHING, FALLING, SPRAYING, OR STANDING LIQUIDS.</li> <li>• CLEAN ONLY WITH LINT-FREE DAMP CLOTH AND DO NOT USE CLEANING AGENTS.</li> <li>• ONLY CONNECT POWER CORD TO A POLARIZED, SAFETY GROUNDED OUTLET WIRED TO CURRENT ELECTRICAL CODES AND COMPATIBLE WITH VOLTAGE, POWER, AND FREQUENCY REQUIREMENTS STATED ON THE REAR PANEL OF THE APPARATUS.</li> <li>• PROTECT THE POWER CORD FROM DAMAGE DUE TO BEING WALKED ON, PINCHED, OR STRAINED.</li> <li>• UNPLUG THE APPARATUS DURING LIGHTNING STORMS OR WHEN UNUSED FOR LONG PERIODS OF TIME.</li> <li>• ONLY USE ATTACHMENTS, ACCESSORIES, STANDS, OR BRACKETS SPECIFIED BY THE MANUFACTURER FOR SAFE OPERATION AND TO AVOID INJURY.</li> <li>• WARNING: TO REDUCE THE RISK OF ELECTRIC SHOCK OR FIRE, DO NOT EXPOSE THIS UNIT TO RAIN OR MOISTURE.</li> <li>• SERVICE MUST BE PERFORMED BY QUALIFIED PERSONNEL.</li> <li>• OUR AMPLIFIERS ARE CAPABLE OF PRODUCING HIGH SOUND PRESSURE LEVELS. CONTINUED EXPOSURE TO HIGH SOUND PRESSURE LEVELS CAN CAUSE PERMANENT HEARING IMPAIRMENT OR LOSS. USER CAUTION IS ADVISED AND EAR PROTECTION IS RECOMMENDED IF UNIT IS OPERATED AT HIGH VOLUME.</li> </ul>		
<p>EXPLANATION OF GRAPHICAL SYMBOLS: EXPLICACION DE SIMBOLOS GRAFICOS: EXPLICATION DES SYMBOLES GRAPHIQUES:</p>	 = "DANGEROUS VOLTAGE" "VOLTAJE PELIGROSO" "DANGER HAUTE TENSION"	 = "IT IS NECESSARY FOR THE USER TO REFER TO THE INSTRUCTION MANUAL" "ES NECESARIO QUE EL USUARIO SE REFIERA AL MANUAL DE INSTRUCCIONES." "REFERREZ-VOUS AU MANUAL D'UTILISATION"

# *Ampeg* SVTDI Vacuum Tube Direct Injection

## Features:

- **PAD SWITCH:** Attenuates the input signal to accommodate “hot” pickups
- **DIRECT/TUBE SWITCHES:** Separate switches for the Thru and Balanced Output jacks - giving you the choice of tube buffered or direct signals at either output jack
- **GROUND LIFT SWITCH:** (Balanced Output jack) Allows you to eliminate hum caused by virtually any situation - whether performing live, or working in the studio
- **TRANSFORMER BALANCED OUTPUT:** The high quality, shielded XLR connector uses an electronic transformer to provide the ultimate balanced output signal
- **AMPEG QUALITY AND COSMETICS:** Lets the world know you mean business

The Front Panel .....	4
The Rear Panel .....	5
Important Information About Tubes And Tube Products .....	6-7
System Block Diagram .....	7

### Declaration Of Conformity

#35, Effective 01-01-2001

**Manufacturer's Name:** SLM Electronics  
**Production Facility:** 1901 Congressional Drive, St. Louis, MO 63146, USA  
**Production Facility:** 700 Hwy 202 W, Yellville, AR 72687, USA  
**Shipping Facility:** 1400 Ferguson Ave., St. Louis, MO 63133, USA  
**Office Facility:** 1400 Ferguson Ave., St. Louis, MO 63133, USA

**Product Type:** Audio Amplifier

**Complies with the following Standards:**

**Safety:** EN60065, E60065, C22.2, UL6500 and/or UL813  
**EMC:** Directive 89/336/EEC, EN55103, EN55013, EN61000,  
and/or FCC 47CFR 15B cIA

Supplementary information provided by:  
SLM Electronics - R & D Engineering  
1901 Congressional Drive, St Louis, MO 63146, USA  
Tel.: 314-569-0141, Fax: 314-569-0175

# Ampeg SVTDI Vacuum Tube Direct Injection

## The Front Panel:

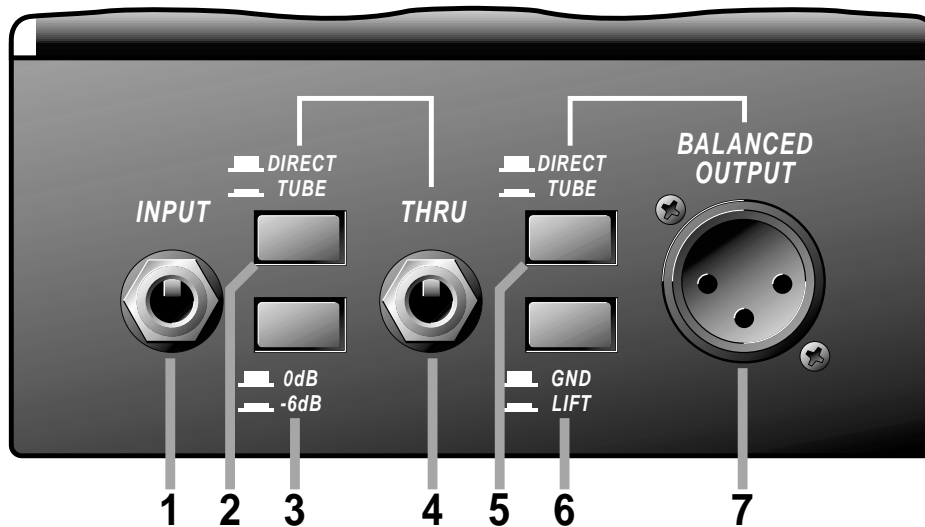

- 1. INPUT:** Connect your line level signal here by means of a shielded signal cable terminated with a male 1/4" connector.
- 2. DIRECT/TUBE:** This switch, when depressed, routes the input signal through the SVTDI's tube stages before sending it to the Thru jack (#4). With this switch in the out position, the input signal is sent directly to the Thru jack, bypassing the buffer tube.
- 3. 0dB/-6dB:** This switch, when depressed, attenuates the input signal by 6dB to compensate for active electronics or other "hot" input signals. With this switch in the out position, the input signal is at its full strength.
- 4. THRU:** Use this jack to connect the output signal to its destination by means of a shielded signal cable terminated with a male 1/4" connector.
- 5. DIRECT/TUBE:** This switch, when depressed, routes the input signal through the SVTDI's tube stages before sending it to the Balanced Output jack (#7). With this switch in the out position, the input signal is sent directly to the Balanced Output jack, bypassing the buffer tube.
- 6. GND/LIFT:** This switch, when depressed, lifts the signal ground at the Balanced Output jack (#7). This is helpful to eliminate hum in the output signal caused by ground loops. With this switch in the out position, the Balanced Output signal ground remains intact.
- 7. BALANCED OUTPUT:** Use this jack to connect the output signal to its destination by means of a shielded signal cable terminated with a male XLR connector.

# Ampeg SVTDI Vacuum Tube Direct Injection

## The Rear Panel:

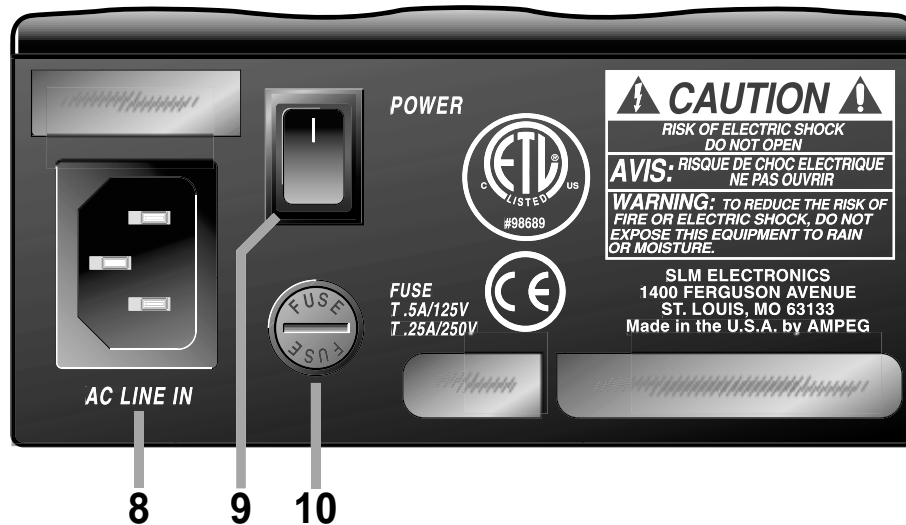

**8. AC LINE IN:** Insert the AC power cord firmly into this socket. The grounded power cord should only be plugged into a grounded power outlet that meets all applicable electrical codes and is compatible with the voltage, power and frequency requirements stated on the rear panel.

**Do not attempt to defeat the safety ground connection!**

**9. POWER:** Use this switch to turn the unit on (top of the switch depressed) and off (bottom of the switch depressed).

**10. FUSE:** This unit employs an external AC line fuse to help protect it from damages due to overload conditions. If the fuse fails, replace it **ONLY** with the same size and type fuse. If the fuse fails repeatedly, discontinue use of the unit and contact your Ampeg Dealer or Authorized Ampeg Service Center for service information.

## **Important Information About Tubes And Tube Products:**

### **A Brief History Of The Tube:**

In 1883, Edison discovered that electrons would flow from a suspended filament when enclosed in an evacuated lamp. Years later, in 1905, Fleming expanded on Edison's discovery and created the "Fleming Valve". Then, in 1907, Dr. Lee de Forest added a third component – the grid – to the "Fleming's Valve" and the vacuum tube was a fact of life. The door to electronic amplification was now open.

During World War II, data gleaned from their intensive research on the detectors used in radar systems led Bell Telephone Laboratories to the invention of the transistor. This reliable little device gained quick support as the new component for amplification. The death of the vacuum tube seemed imminent as designers, scientists, and engineers reveled in the idea of replacing large, fragile glass tubes with these small, solid-state devices.

However, there were (and still are) many serious listeners who realized that the sound produced by a "transistor" amplifier is significantly different from that produced by a tube amplifier with identical design specifications. They considered the sound produced by these new solid-state devices to be hard, brittle, and lifeless. It was determined that solid-state devices produced a less musical set of harmonics than tubes. When pushed past their limits, they tend to mute the tone and emphasize the distortion.

Tubes, on the other hand, produce a more musical set of harmonics, the intensity of which can be controlled by the player. This characteristic adds warmth and definition to the sound which has become the hallmark of tube amplifiers. When tubes are driven into clipping, the harmonic overtones can be both sweet and pleasing or intense and penetrating, depending on the musician's musical taste and playing technique.

Over the years, application engineers have designed a number of outstanding solid-state amplifiers that sound very, very good. Some use special circuitry which enables them to simulate the distortion characteristics of a tube amplifier. However, the tube amplifier, still held in the highest esteem by many musicians, offers a classic "vintage" sound in a contemporary market.

### **Preampifier Tube types And Usage:**

The tubes used in preamplifiers (12AX7, 12AU7, 12AT7, etc.) amplify the signal from your instrument and shape the sound. They are inherently microphonic (mechanically pick up and transmit external noises). Since these tubes are used in the critical first stages of a tube preamplifier's circuitry, it is very important to use high-quality, low noise/low microphonic tubes for this application. Although tubes of this quality may be difficult to find and typically cost more than "off-the-shelf" tubes, the improvement in performance is worth the investment.

### **The Nature Of Tubes: Why (And When) To Replace Them:**

Tubes are made up of a number of fragile mechanical components that are vacuum-sealed in a glass envelope or bubble. The tube's longevity is based on a number of factors which include how hard and often the equipment is played, vibration from the speakers, road travel, repeated set up and tear down, etc.

If your preamplifier squeals, makes noise, loses gain, starts to hum, lacks "sensitivity", or feels as if it is working against you, the preamplifier tubes may need to be replaced. Remember to use only high quality, low microphonic tubes.

If you're on the road a lot, we recommend that you carry a set of replacement tubes.

## Important Information About Tubes And Tube Products:

### Survival Tips For Tube Preamps:

To prolong tube life, observe these tips and recommendations:

- After using the preamplifier, allow sufficient time for it to properly cool down prior to moving it. A properly cooled preamplifier prolongs tube life due to the internal components being less susceptible to the damage caused by vibration.
- Allow the preamplifier to warm up to room temperature before turning it on. The heat generated by the tube elements can crack a cold glass housing.
- Protect the preamplifier from dust and moisture. If liquid gets into the preamplifier proper, or if the preamplifier is dropped or otherwise mechanically abused, have it checked out at an authorized service center before using it.
- Proper maintenance and cleaning in combination with routine checkups by your authorized service center will insure the best performance and longest life from your preamplifier.

***CAUTION: Tube replacement should be performed only by qualified service personnel who are familiar with the dangers of hazardous voltages that are typically present in tube circuitry.***

### System Block Diagram:

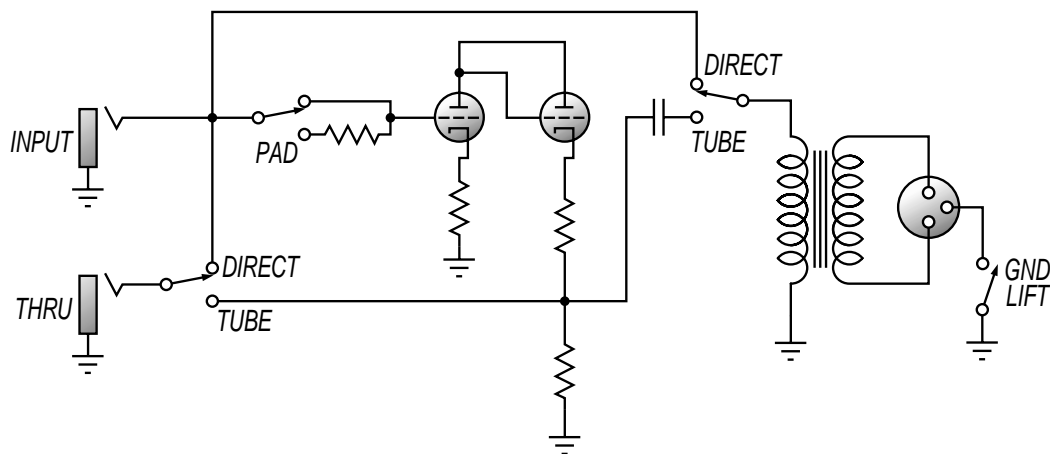

# *Ampeg* SVTDI Vacuum Tube Direct Injection

---

## TECHNICAL SPECIFICATIONS:

---

<b>GAIN (+/-1dB)</b>	at THRU jack:	Direct = 0dB; Tube = 0dB
	at BAL OUT:	Direct = -14dB; Tube = -14dB
	PAD:	-6dB (active only in Tube modes)

---

<b>FREQ RESPONSE</b>	at THRU jack:	20-20kHz, +/- .5dB
	at BAL OUT:	10-70kHz, +/- 1dB

---

<b>MAXIMUM INPUT SIGNAL</b>	2.5V RMS
-----------------------------	----------

---

<b>MAXIMUM BAL. OUT SIGNAL</b>	0.5V RMS
--------------------------------	----------

---

<b>SIGNAL TO NOISE RATIO</b>	> 90dB
------------------------------	--------

---

<b>DIMENSIONS</b>	2.5" H x 5.25" W x 8.5" D
-------------------	---------------------------

---

<b>WEIGHT</b>	5 lbs.
---------------	--------

---

Ampeg continually develops new products, as well as improves existing ones. For this reason, the specifications and information in this manual are subject to change without notice.

---



[www.ameg.com](http://www.ameg.com)



©2003 AMPEG, 1400 Ferguson Avenue, St. Louis, MO 63133 U.S.A.

47-339-01 • 122903