

TEST POINT CONDITIONS:
INPUT = .64 Vrms @ 1KHz, ALL SLIDERS @ CENTER DETENT.

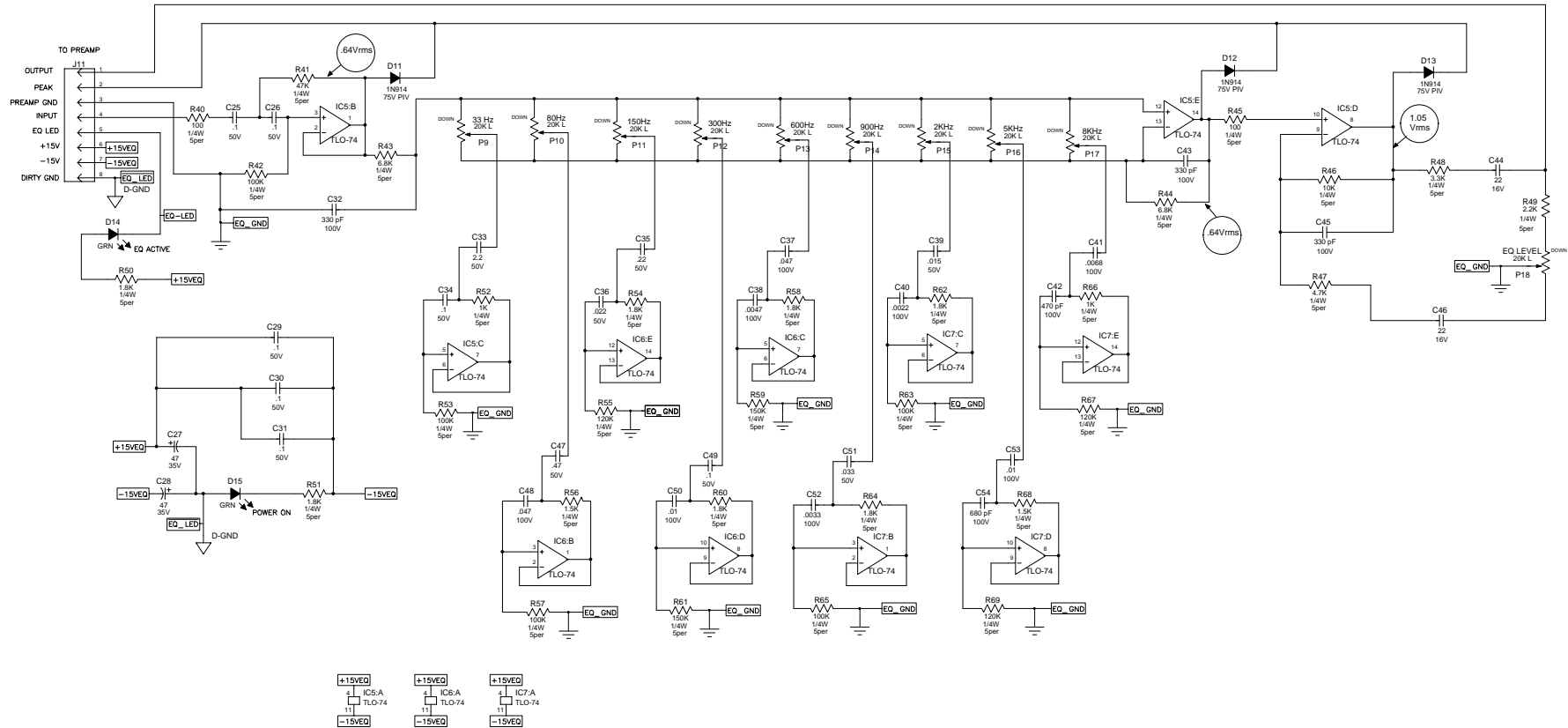

ASSY PART # 07-313-01

CAUTION:
THIS SCHEMATIC IS PROVIDED FOR USE BY QUALIFIED PERSONNEL.
TO AVOID RISK OF ELECTRIC SHOCK, REFER SERVICING TO QUALIFIED
SERVICE PERSONNEL. DO NOT PERFORM ANY SERVICING BEYOND
THAT EXPLAINED IN THE OPERATING INSTRUCTIONS.

- NOTES:
- 1) CAUTION: SHOCK HAZARD!!
THIS UNIT CONTAINS HAZARDOUS VOLTAGE. DISCONNECT POWER
AND BE SURE POWER SUPPLY IS DISCHARGED BEFORE
TOUCHING INTERNAL PARTS.
 - 2) UNLESS NOTED, RESISTOR VALUES IN OHMS, 1/8W-5% TOL.
CAPACITOR VALUES IN MICROFARADS, 50V-10% TOL.
 - 3) VOLTAGES ARE MEASURED WITH 1 MEGOHM OSCILLOSCOPE
AND 10 MEGOHM DIGITAL VOLTMETER.

0	7/28/04	CONTROL ISSUE				WFB
A	6/17/04	INITIAL ISSUE				
REV	Date	DESCRIPTION	Ecr(s)/Ecn(s)	Chgd By	Appvd by	Date
THE INFORMATION CONTAINED ON THIS DRAWING IS PROPRIETARY TO ST. LOUIS MUSIC, INC.						
Signatures:			Date:		 1901 Congressional, St. Louis, MO 63146	
Drawn: REM			5/05/04			
Checked:						
Released:					First Used On:	
Plot Date: Wed Jul 28, 2004		Drawing Size: C		Drawing Title: PWA - BASS EQ		
Plot Time: 13:34:51		Drawing Type: Schematic		Drawing Number: 07S313		
Tolerance:		Class Code: NONE		Sheet 1 of 1		